

Dynabelter®

**1" Wide Abrasive Belt Capacity
 For Serial Number 8751 and Higher**

Models:
 11462 – Standard Duty/Finisher
 11475 – Standard Duty
 11476 – Heavy Duty

⚠ WARNING

Always operate, inspect and maintain this tool in accordance with the Safety Code for portable air tools (ANSI B186.1) and any other applicable safety codes and regulations. Please refer to Dynabrade's Warning/Safety Operating Instructions for more complete safety information.

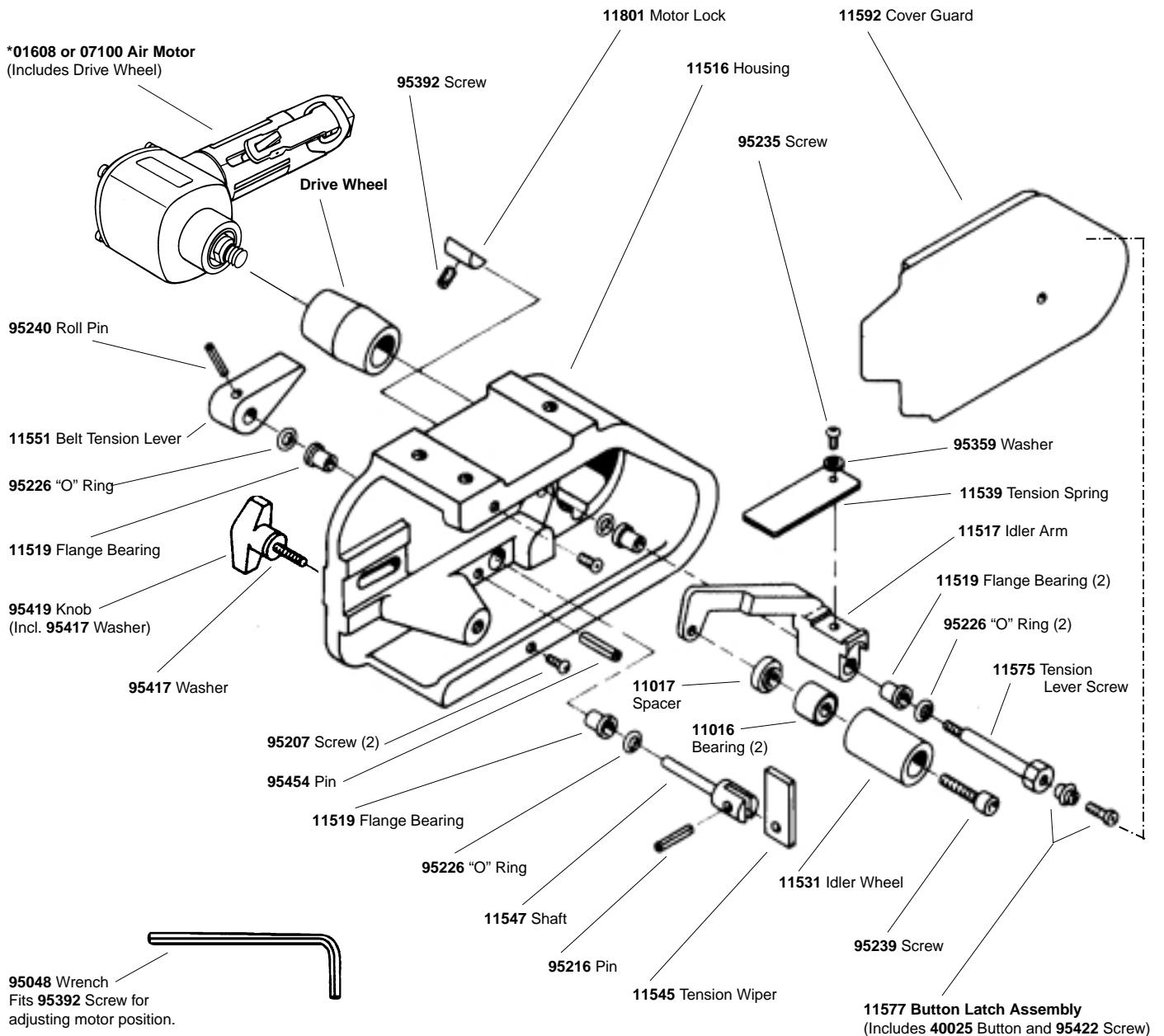

See page 3 for Standard Contact Arm Assemblies.

***See page 2 for 01608 and 07100 Motor Assemblies.**

**Note: To order replacement parts specify the model and serial number of your machine.
 See page 7 for Important Operating/Maintenance and Safety Instructions before operating this tool.**

Standard Duty Air Motor 01608 — Powers Model 11462 & 11475 Dynabelter® (Includes 14230 Drive Wheel)

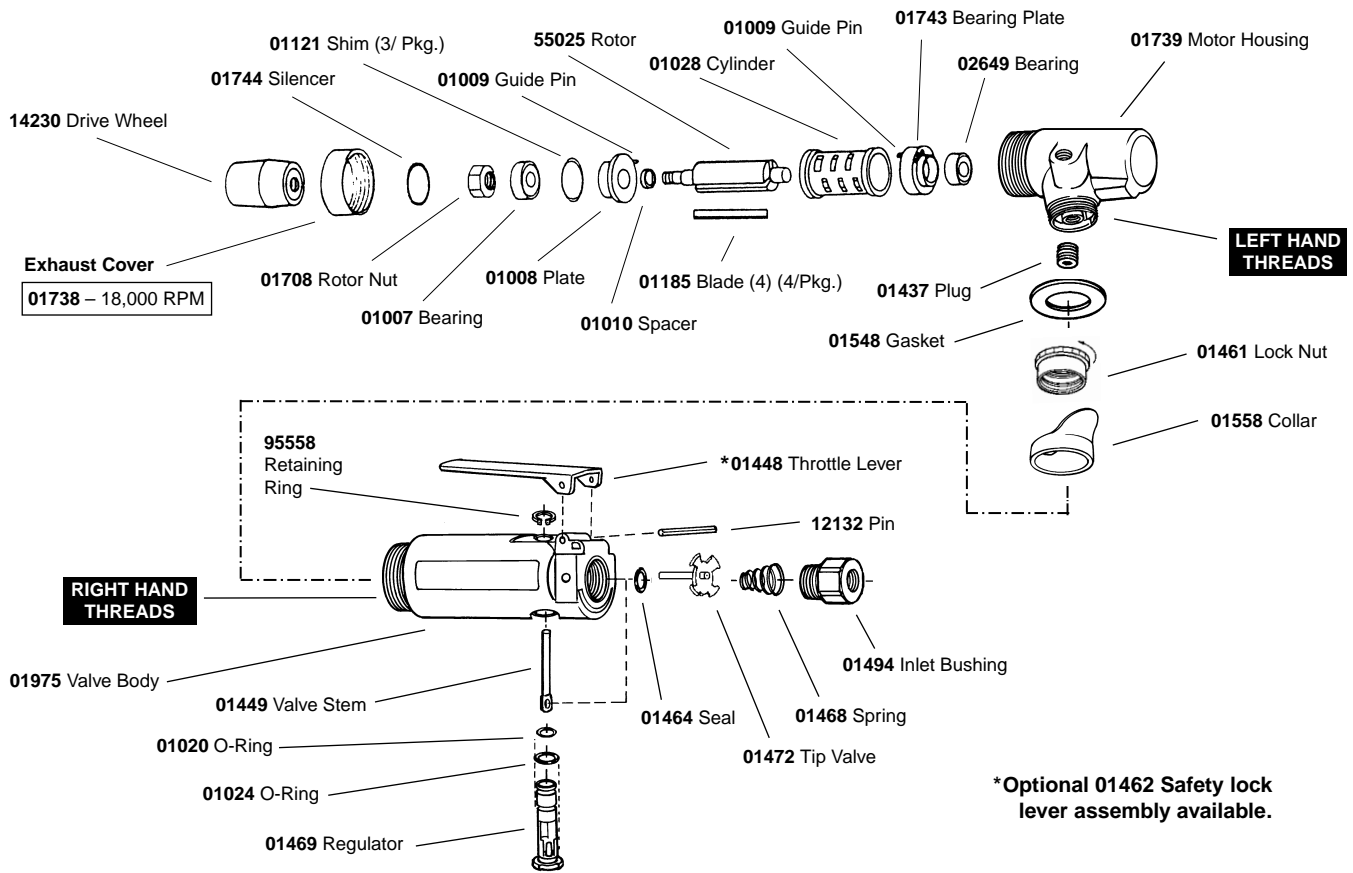

Heavy-Duty Air Motor 07100 — Powers Model 11476 Dynabelter® (Includes 11518 Drive Wheel)

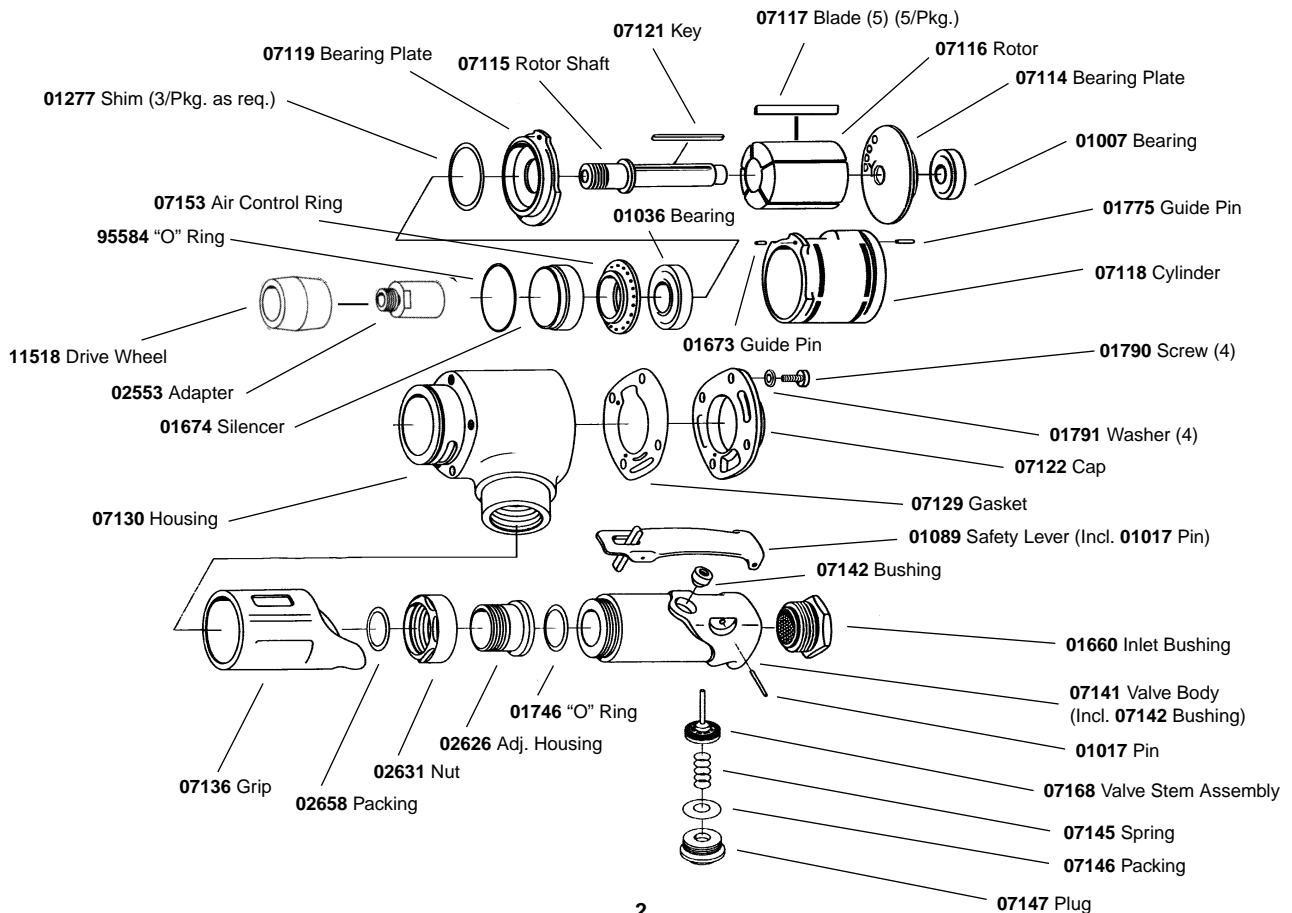

Dynabelter® Standard Contact Arm Assemblies

11681 Standard Contact Arm Assembly, for Models 11475 and 11476.

Belt Size: 1" wide x 30" long.

Contact Wheel: 1" wide x 2" diameter. 70-Duro standard serrated urethane. (Other wheels may be substituted, see chart on page 5).

Platen Pad: 1" wide x 2-1/2" long.

Shaded parts indicate **11650 Contact Wheel Assembly**.

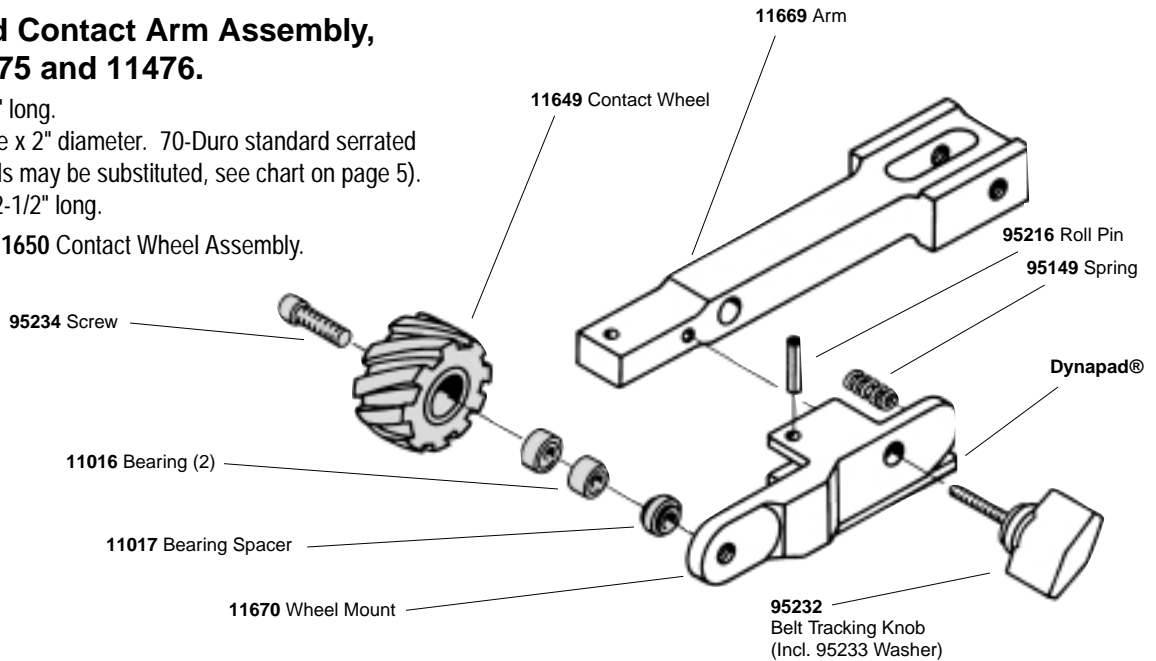

11601 Standard Contact Arm Assembly, for Model 11462

Belt Size: 1" wide x 60" long.

Contact Wheel: 1" wide x 4" diameter. 40-Duro smooth rubber.

Shaded parts indicate **11620 Contact Wheel Assembly**.

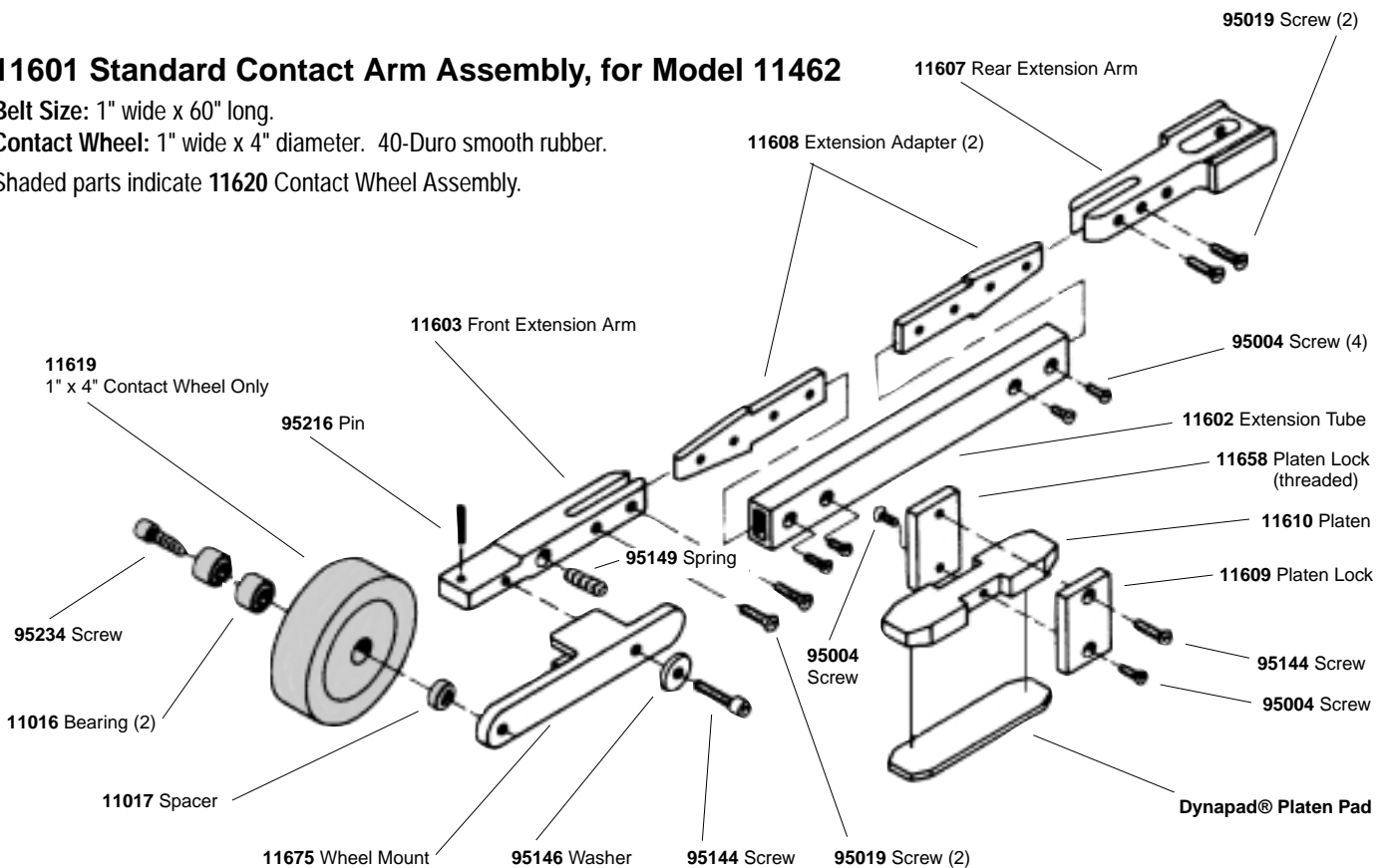

The **11462** Dynabelter® Finisher normally uses 1" wide x 60" long abrasive belts. The **11602** Extension Tube can be modified to accommodate various belt lengths.

Optional Contact Arm Assemblies

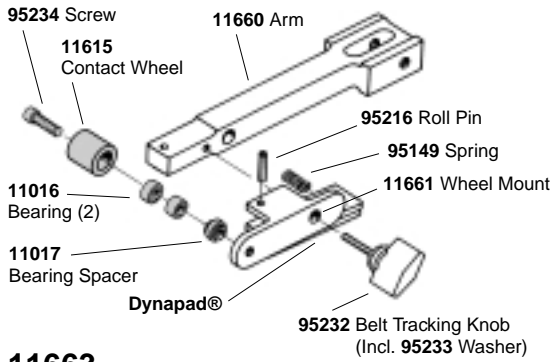

11663

Belt Size: 1" wide x 30" long.
Contact Wheel: 1" wide x 1" diameter. 80-Duro smooth rubber.
Platen Pad: 1" wide x 2-1/2" long.
 Shaded parts indicate 11616 Contact Wheel Assembly.

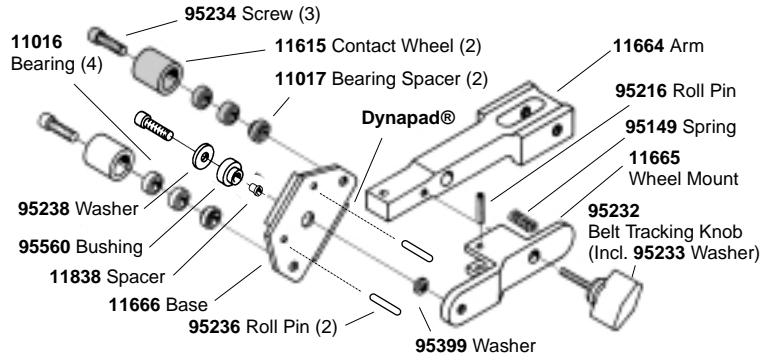

11668 "Stroke Sander"

Belt Size: 1" wide x 30" long.
Contact Wheel: 1" wide x 1" diameter. 80-Duro smooth rubber.
Platen Pad: 1" wide x 1-7/8" long.
 Shaded parts indicate 11616 Contact Wheel Assembly (2 included).

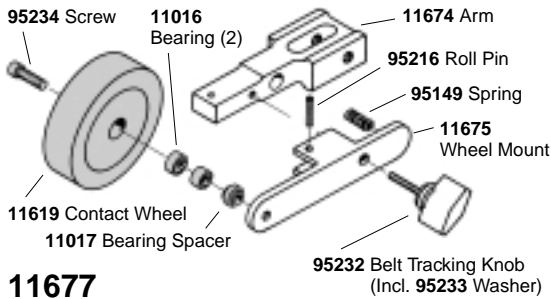

11677

Belt Size: 1" wide x 30" long.
Contact Wheel: 1" wide x 4" diameter. 40-Duro smooth rubber.
Note: 80-Duro available.
 Shaded parts indicate 11620 Contact Wheel Assembly.

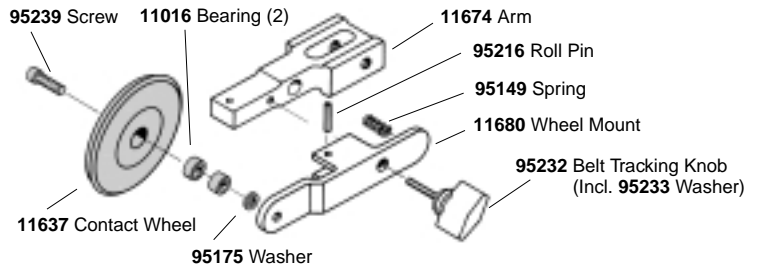

11682

Belt Size: 1/2" or 1" wide x 30" long.
Contact Wheel: 1" wide x 4" diameter. 70-Duro radiused rubber.
 Shaded parts indicate 11638 Contact Wheel Assembly.

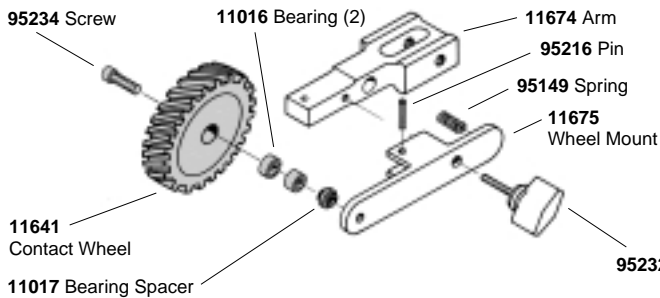

11684

Belt Size: 1" wide x 30" long.
Contact Wheel: 5/8" wide x 4" diameter. 40-Duro standard serrated rubber.
 Shaded parts indicate 11642 Contact Wheel Assembly.

Note: Arm extenders are available: 11656 for 42" belts; 11657 for 54" belts; 11679 for 60" belts.

Optional Contact Arm Assemblies (continued)

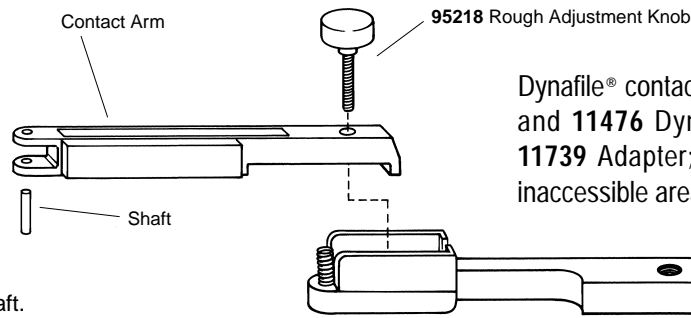
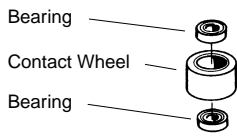

Dynaflex® contact arms can be mounted on **11475** and **11476** Dynabelter® models with optional **11739** Adapter; allows work in small, normally inaccessible areas using 30" belts (8" reach).

Contact Wheel Assembly –
Includes wheel, bearings and shaft.

11739 Adapter
(Includes **95218** Rough Adj. Knob)

Dynaflex® Contact Arms for use with Dynabelter (11739 Adapter)

Part Number	Abrasive Belt Size	Contact Wheel Description	Contact Wheel Assembly	Contact Wheel Only	Bearing (2) Req.	Shaft
11212	1/4" x 24"	5/16" Dia. x 1/8" W Steel	11066	11065	11051 (1)	11056
11213	1/2" x 24"	5/16" Dia. x 3/8" W Steel	11068	11067	11051	11054
11214	1/2" x 24"	7/16" Dia. x 3/8" W Rubber	11070	11069	11051	11054
11215	1/4" x 24"	7/16" Dia. x 1/8" W Brass	11072	11071	11052 (1)	11053
11216	1/4" x 24"	5/8" Dia. x 1/8" W Rubber	11074	11073	11052 (1)	11053
11217	1/2" x 24"	1/2" Dia. x 3/8" W Steel	11076	11075	11052	11054
11218	1/2" x 24"	5/8" Dia. x 1/8" W Rubber	11078	11077	11052	11054
11219	1/4" or 1/2" x 24"	1" Dia. x 3/8" W Radiused Rubber	11080	11079	11052	11054
11228	1/2" x 24"	5/8" Dia. x 3/8" W Rubber	11078	11077	11052	11054
11231	1/2" x 24"	3/4" Dia. x 1/2" W Rubber	11084	11083	11052	11055
11232	1/8" or 1/4" x 24"	1" Dia. x 3/8" Tapered Urethane	11086	11085	11052	11054
11239	1/2" x 24"	5/16" Dia. x 3/8" W Steel	11068	11067	11051	11054
11243	1/2" x 24"	3/4" Dia. x 1/2" W Rubber	11084	11083	11052	11055

Accessories

11548 Top Handle Assembly

Mounts to top of machine housing.
Standard on Model **11476**.
Optional for Model **11475**.

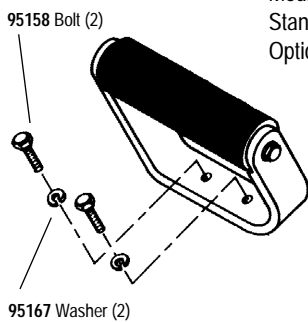

11705 Pressure Bar Assembly

Mount to top of machine housing.
Standard on Model **11462**.
Optional for Models **11475** and **11476**.

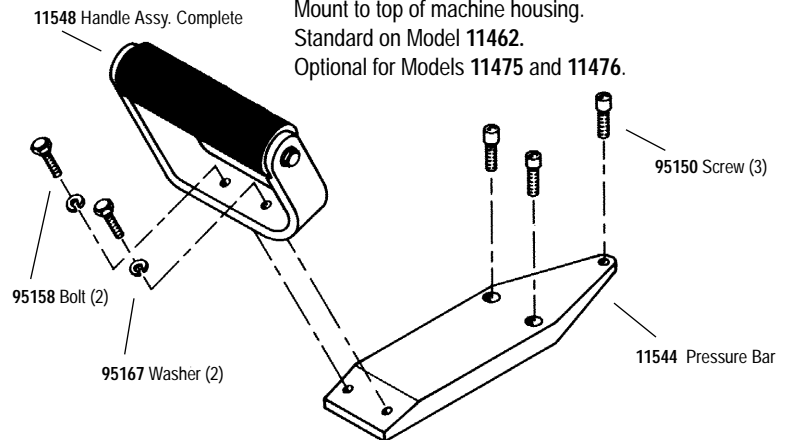

11535 Side Handle

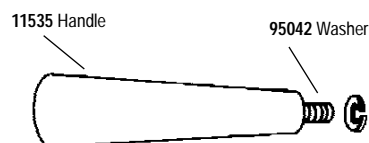

Mount to side of machine housing.
Standard on Model **11475**.
Optional for Models **11462** and **11476**.

Optional Accessories

1" x 2" Urethane Wheel Assemblies Available for 11681 Contact Arm Assembly

Durometer	Serration	Color	Part No.
90	Scoop	Amber	11614
90	Standard	Amber	11618
80	Standard	Blue	11652
70	Standard	Green	11650
60	Standard	Red	11648

Note: Higher durometer indicates harder wheel for more aggressiveness. Scoop serration also is more aggressive than standard serration.

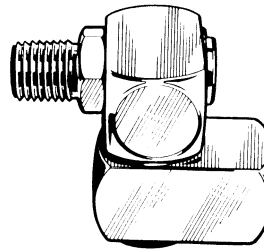

Dynaswivel®

Swivels 360° at two locations which allows an air hose to drop straight to the floor, no matter how the tool is held.

- 95460 1/4" NPT
- 95461 3/8" NPT
- 95462 1/2" NPT

Dynapad® Platen Pads – Mounts to tool contact arm to provide abrasive belt support.

Part No.	Used on these Contact Arms	Size	Material	Pkg. Qty.
11025	Dynafile®	1/2" W x 7" L x 1/8" Thk	Soft/Sponge	5
11026	Dynafile®	1/2" W x 7" L x 1/8" Thk	Hard/Cork	5
11027	Dynafile®	1/2" W x 7" L x 1/32" Thk	Thin	5
11028	Dynafile®	1/2" W x 3" L x 1/8" (bolts on 11228 Contact Arm)	Steel	1
11032	Dynafile®	1/4" W x 7" L x 1/8" Thk	Soft/Sponge	5
11033	Dynafile®	1/4" W x 7" L x 1/8" Thk	Hard/Cork	5
11034	Dynafile®	1/4" W x 7" L x 1/32" Thk	Thin	5
11604	Dynabelter®	1" W x 7" L x 1/8" Thk	Soft/Sponge	5
11605	Dynabelter®	1" W x 7" L x 1/8" Thk	Hard/Cork	5
11814	Dynabelter®	2" W x 7" L x 1/8" Thk	Hard/Cork	1
11834	Dynabelter®	2" W x 7" L x 1/8" Thk	Soft/Sponge	1

Note: All Dynapad Platens PSA mounted except 11028. Cork and sponge-base platen pads easily trimmed to size. Unit = 10 pkgs. each.

Soft
For deburring and polishing contoured pieces.

11025 – 1/2" W x 7" L x 1/8" Thk. – 5/pkg.
11119 – 3/4" W x 7" L x 1/8" Thk. – 5/pkg.

Hard
For heavy deburring and polishing

11026 – 1/2" W x 7" L x 1/8" Thk. – 5/pkg.
11109 – 3/4" W x 7" L x 1/8" Thk. – 5/pkg.

Thin
For aggressive grinding.

11027 – 1/2" W x 7" L x 1/32" Thk. – 5/pkg.
11129 – 3/4" W x 7" L x 1/32" Thk. – 5/pkg.

Metal
For flat grinding and heavy stock removal; bolts to contact arm.

11028 — 1/2" W x 3" L (for Dynafile II 11228 Arm only)

Abrasive Belts

Coated Aluminum Oxide/30" Long

Tough, durable synthetic used for work on high carbon steels, general metalworking and certain hardwoods.

2" Wide/Unit = 50 Belts. All others/Unit = 200 Belts

Part Numbers

Grit	1/4" W	1/2" W	1" W	2" W
36	—	90501	90507	90385
60	90466	90502	90509	90386
80	90468	90492	90510	90387
120	90470	90504	90511	90389
180	90471	90493	90512	90390
220	—	90494	90513	90391
320	90473	90496	90514	90392
500	—	90498	90516	90539

60" Long — For use with 11679 Contact Arm Extender

60	—	—	94621	94611
80	—	—	94622	94612
120	—	—	94623	94613

Coated Aluminum Zirconia/30" Long

Synthetic grain with self-sharpening characteristics providing continuous new cutting edges for greater efficiency.

2" Wide/Unit = 50 Belts. All others/Unit = 200 Belts

Part Numbers

Grit	1/4" W	1/2" W	1" W	2" W
36	—	90500	90506	90520
60	—	90503	90508	90523
80	—	90505	90518	90524

Abrasive Impregnated Non-Woven Nylon/30" Long

Mineral is impregnated in non-woven fiber. Results in consistent surface conditioning and cleaning.

Unit = 12 Belts

Very Fine	—	90406	90401	90414
Medium	—	90436	90437	90438
Coarse	—	90442	90444	90448

Cloth Polishing Belts/30" Long

Unit = 25 Belts

—	—	—	90015	—
---	---	---	-------	---

Important Operating, Maintenance and Safety Instructions

Carefully read all instructions before operating or servicing any Dynabrade® Abrasive Power Tool.

Warning: Hand, wrist and arm injury may result from repetitive work motion and overexposure to vibration.

Operating Instructions:

Warning: Eye, face and body protection must be worn while operating power tools. Failure to do so may result in serious injury or death. Follow safety procedures posted in workplace.

1. With power source disconnected from tool, securely position abrasive belt on tool (see abrasive belt/contact arm change instructions).
2. Connect power source to tool. Be careful **not** to depress throttle lever in the process.
3. Check tool speed with tachometer. If tool is operating at a higher speed than the RPM marked on the tool or operating improperly, the tool should be serviced to correct the cause before use.
4. Always work off the return side of the abrasive belt. This will ensure superior tracking and less down time of machine.

Abrasive Belt/Contact Arm Change Instructions:

To Change Belt:

1. Disconnect power source.
2. Remove 11592 Cover Guard.
3. Release 11551 Belt Tension Lever.
4. Pull belt backwards and to the left until belt is released from drive wheel.
5. Reverse process for applying new belt.
6. Connect power source.
7. Depress throttle lever to start motor and belt rotation.
8. Adjust belt tracking by turning 95232 Belt Tracking Knob on contact arm assembly to the left or right accordingly.

To Change Contact Arm Assembly:

1. Disconnect power source.
2. Remove 11592 Cover Guard.
3. Remove abrasive belt (see instructions).
4. Remove 95419 Rough Adjustment Knob.
5. Remove Contact Arm and replace with desired contact arm.
6. Replace 95419 Knob. Do not tighten knob at this point.
7. Replace abrasive belt.
8. With abrasive belt in proper position, push contact arm assembly forward until the contact wheel is tight against abrasive belt.
9. Tighten 95419 Knob.
10. Replace 11592 Cover Guard.
11. Reset 11551 Belt Tension Lever.
12. Connect power source and depress throttle lever to start motor and abrasive belt rotation.
13. Adjust belt tracking by turning 95232 Belt Tracking Knob on contact arm assembly to the left or right accordingly.

Maintenance Instructions:

Products offered by Dynabrade should not be converted or otherwise altered from original design without expressed written consent from Dynabrade, Inc. All Dynabrade air tools must be used with a filter-regulator-lubricator to maintain all warranties.

1. Check tool speed regularly with a tachometer. If tool is operating at a higher speed than the RPM marked on the tool, the tool should be serviced to correct the cause before use.
2. Some silencers on air tools may clog with use. Clean and replace as required.
3. All Dynabrade air motors should be lubricated with two drops of Dynabrade Air Lube (P/N 95842: 1pt. 473ml.) every four hours of use.
4. An air line filter-regulator-lubricator must be used with this air tool to maintain all warranties. Dynabrade recommends the following:
11299 Air Line Filter- Regulator-Lubricator — Provides accurate air pressure regulation, two-stage filtration of water contaminant's and micro-mist lubrication of pneumatic components. Operates 100 CFM @ 90 PSI has 1/2" NPT female ports.

Safety Instructions:

- **Important:** User of tool is responsible for following accepted safety codes such as those published by the American National Standards Institute (ANSI).
- **Warning:** Eye, face and body protection must be worn when operating power tools. Failure to do so may result in serious injury or death.
- Products offered by Dynabrade should not be converted or otherwise altered from original design without the expressed written consent of Dynabrade, Inc..
- Tool RPM rating must never exceed abrasive/accessory RPM rating, regardless of tools capacity.
- Operate machine for one minute before application to workpiece to determine if machine is working properly and safely before work begins.
- Always use proper guards. Make sure guards are in proper position, secure and in good repair.
- Always disconnect power supply before changing abrasive or making machine adjustments.
- Inspect abrasives for damage or defects prior to installation on tools. Make sure belts are mounted properly; check for proper tension and belt tracking.
- Please refer to Dynabrade's Warning/Safety Operating Instructions Tag (Reorder No. 95903) for more complete safety information.



DYNABRADE

Toll Free (USA) 1-800-828-7333

Toll Free (Can.) 1-800-344-1488