



Industrial Downdraft Table

Operating Manual

Models:

E-5075 (33 in. x 65 in.)

E-5076 (33 in. x 73 in.)



Model: E-5075

Keep workplace area free of contaminants while sanding and finishing wood or non-combustible materials.

Keep machine running when not in use to help clean the shop environment.



SAFETY LEGEND



⚠ WARNING

Read and understand tool manual before work starts to reduce risk of injury to operator, visitors, and tool.

⚠ WARNING

Practice safety requirements. Work alert, have proper attire, and do not operate tools under the influence of alcohol or drugs.



⚠ WARNING

Eye protection must be worn at all times, eye protection to conform to ANSI Z87.1.

⚠ WARNING

Ear protection to be worn when exposure to sound, exceeds the limits of applicable Federal, State or local statutes, ordinances and/or regulations.



⚠ WARNING

Respiratory protection to be used when exposed to contaminants that exceed the applicable threshold limit values required by law.

⚠ WARNING

Electric shock hazard. Avoid bodily contact with grounded objects, bodies of water. Do not damage cord set.



IMPORTANT SAFETY INSTRUCTIONS

When operating this equipment, basic precautions should always be strictly followed including the instructions listed below:

DOWNDRAFT TABLE SAFETY INSTRUCTIONS

1. Always use a grounded power supply. There is an increased risk of electric shock with an ungrounded power supply.
2. Don't expose to rain or wet conditions. There is an increased risk of electric shock if the switch, cord or motor are wet.
3. Do not abuse the power cord. Never use the cord to move the table. Never use the cord to pull the plug from an outlet. A damaged cord increases the risk of electric shock.
4. Use caution when opening or closing the top. Switch power off and unplug cord before opening top. Remove all work pieces and

tools before opening top to avoid injury. Keep fingers and hands clear when closing the top to avoid injury.

5. Never use to exhaust chemical vapors
6. Vibration may occur if unit is unlevel.
7. Unplug power cord when accessing blower compartment area.
8. Power switch must be off when servicing filter.
9. Do not use this table to sand or grind materials that may create sparks.
10. Do not use for explosive metallic dust (Aluminum, Magnesium, etc.)

IMPORTANT NOTICE

COMPLETE ASSEMBLY DIAGRAM

See page 3 for Label Identification

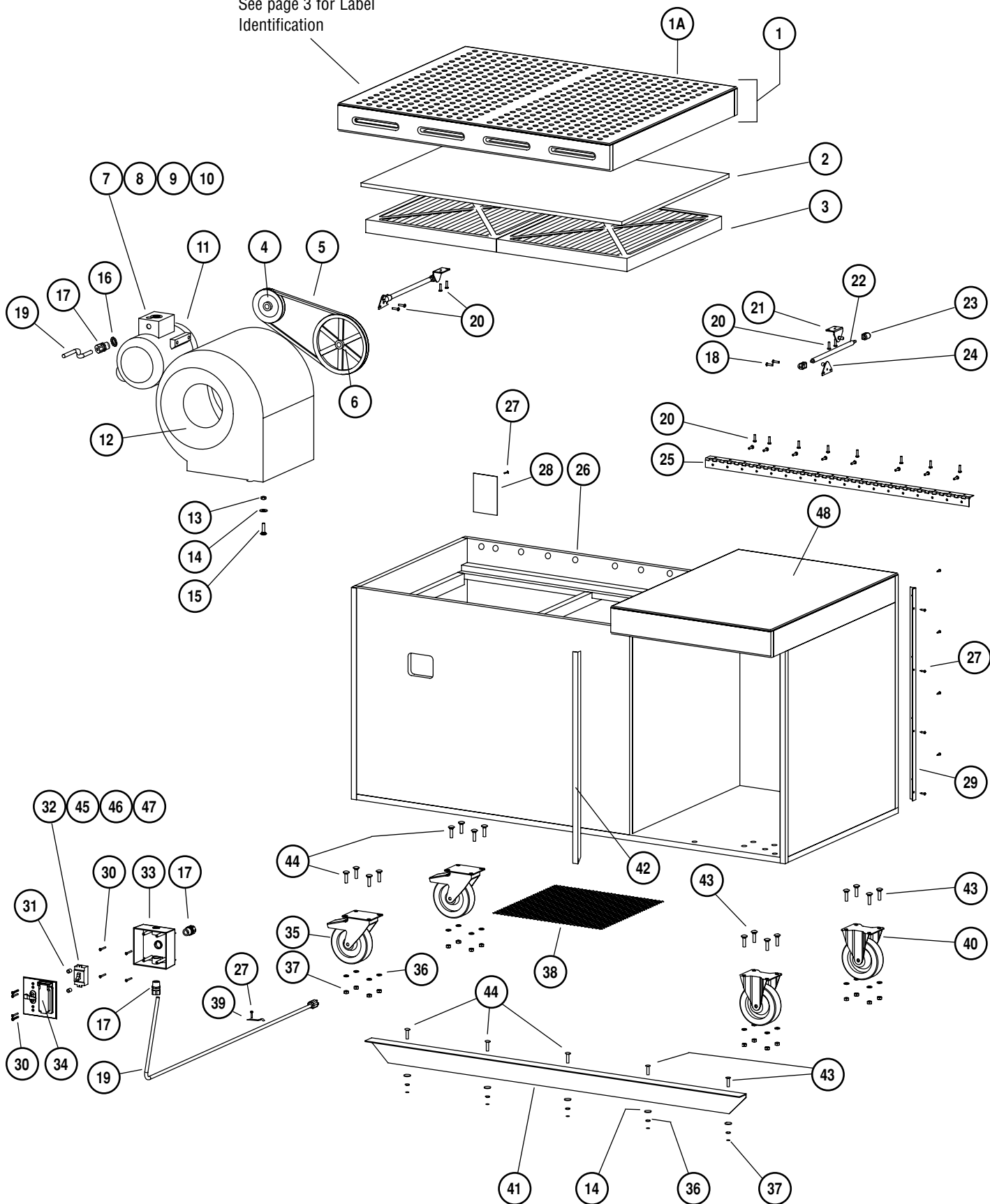

REPLACEMENT PARTS

ITEM NO.	PART NO.	DESCRIPTION	QTY.
1	E-5248	Complete Downdraft Table Top Assembly	1
1A	E-5071	Downdraft Table Top (Top - Only)	1
2	64985	Pre-Filter	1
3	64671	Air Filter	2
4	64214	Sheave	1
5	64215	V-Belt	1
6	64213	Sheave	1
7	98609	Terminal	13
8	98421	115V Label	1
9	98420	Arrow Label	1
10	98615	Wire Connector	1
11	64212	1hp Motor	1
12	64211	Blower	1
13	64239	Hex Nut (Nylon Insert)	4
14	95183	Washer	13
15	64237	Bolt	4
16	98746	Lock Nut	1
17	98701	Cord Grip	3
18	64236	Screw	2
19	64233	Cord (Note: Specify Length)	See Note
20	64230	Screw	26
21	64225	Bracket	2
22	64222	Gas Shock/Spring	2
23	64223	Ball Socket	4
24	64224	Bracket	2
25	64220	Hinge	1
26	64226	T-Nut	28
27	64234	Screw	42
28	65059	Name Plate	1
29	64228	Corner Guard - E-5075	4
29	64259	Corner Guard - E-5076	4
30	64229	Screw	10
31	97340	Spacer	2
32	64240	Switch	1
33	64216	Outlet Box	1
34	64217	Cover	1
35	64218	Locking Caster	2
36	95042	Lock Washer	21
37	97216	Nut	21
38	64227	Wire Mesh	1
39	64231	Cable Strap	2
40	64219	Rigid Caster	2
41	64221	Support Bar	1
42	64238	Inner Corner Guard	1
43	64235	Bolt	10
44	64232	Bolt	11
45	98409	Wire	6"
46	98411	Wire	6"
47	98616	Wire Connector	3
48	E-5070	Table Top (Top - Only)	1

LABEL IDENTIFICATION



64679
Replacement
Filter Label



64696
Electric Warning Label



64697
Spark Warning Label



64698
Information Label

SET-UP/OPERATING/MAINTENANCE INSTRUCTIONS

DOWNDRAFT TABLE SET UP INSTRUCTIONS

1. Make sure power cord is unplugged from power supply.
2. Install two rigid casters and two swivel casters into position as shown on complete assembly diagram (pg. 2).
3. Position table in work area and lock swivel casters to stabilize the table.
4. Install provided filters and pre-filter.
5. Make sure top is closed and power switch is off before plugging cord into grounded power supply.

DOWNDRAFT TABLE OPERATING AND MAINTENANCE INSTRUCTIONS

1. Switch power on to begin dust collection.
2. Do not block more than 50% of inlet holes during use.
3. Do not obstruct outlet.
4. Switch power off and unplug cord before opening top.
5. Clean pre-filter and pleated filters daily.
6. Clean top surface only with brush or dry cloth as necessary.
7. Do not use alcohol on top surface.
8. Replace filters every 30-60 days as necessary.
9. Vacuum filter support rails regularly to assure proper seating.

MACHINE SPECIFICATIONS

Model Number	Motor hp (W)	Voltage	Phase	Vacuum Suction	Sound Level	Working Area Width	Working Area Length	Height Inch (cm)	Shipping Weight
E-5075	1 (746)	110/220	1	3,000 SCFM	72 dB(A)	33" (84 cm)	41" (104 cm)	36 (91)	365 lbs.
E-5076	1 (746)	110/220	1	3,000 SCFM	72 dB(A)	33" (84 cm)	41" (104 cm)	36 (91)	365 lbs.

OPTIONAL ACCESSORIES

REPLACEMENT FILTERS

- 64671** Standard Paper Air Filter
- 64672** UL Rated Class I Non-Flammable Air Filter

REPLACEMENT PRE-FILTERS

- 64985** 33 in. x 41 in.

Note: Filters sold separately / 12 Filters per case

DYNABRADE CUSTOMER SERVICE

US Consumers Call Toll-Free: 1-800-828-7333 • Canadian Consumers Call Toll-Free: 1-800-344-1488

DYNABRADE, INC.

8989 Sheridan Drive • Clarence, New York 14031-1490 • Phone: (716) 631-0100
Fax: 716-631-2073 • US Consumers Call Toll Free: 1-800-828-7333

DYNABRADE INTERNATIONAL

8989 Sheridan Drive • Clarence, New York 14031-1490 • Phone: (716) 631-0100
Fax: 716-631-2524 • Canadian Consumers Call Toll Free: 1-800-344-1488

DYNABRADE EUROPE S.à r.l.

Zone Artisanale • L-5485 Wormeldange-Haut, Luxembourg
Phone: +352 768 494 1 • Fax: +352 768 495

DYNABRADE DO BRASIL

Rua Mário Fongaro • 421 – Vila Marlene • São Bernardo do Campo
SP – CEP 09732-530 • Telefax: (11) 4124-6040

www.dynabrade.com

