



# SERVICE PARTS LIST

**BULLETIN NO.**  
**54-06-2165**

SPECIFY CATALOG NO. AND SERIAL NO. WHEN ORDERING PARTS		REVISED BULLETIN	DATE
<b>RADIUS LED TEMPORARY SITE LIGHT</b>			Nov. 2018
CATALOG NO. <b>2156-AC</b>	STARTING SERIAL NO. <b>K45A</b>	WIRING INSTRUCTION	

**EXAMPLE:**  
Component Parts (Small #)  
Are Included When Ordering  
The Assembly (Large #).

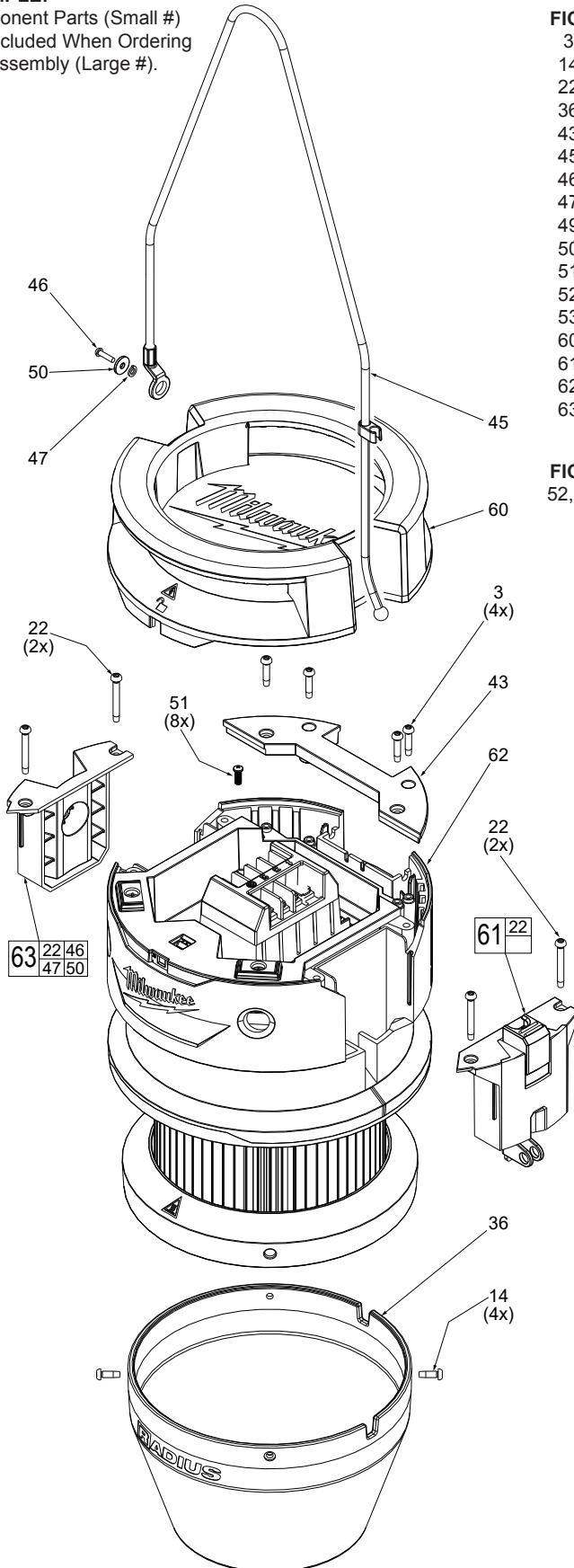

FIG.	PART NO.	DESCRIPTION OF PART	NO. REQ.
	3	M4 x 18mm Pan Hd. ST T-20 Screw	(4)
	14	M4 x 12mm Pan Hd. ST Phillips Screw	(4)
	22	M4 x 32mm Pan Hd. ST T-20 Screw	(4)
	36	Lens	(1)
	43	Hinge Cover	(1)
	45	Cable Assembly	(1)
	46	M3 x 12mm Pan Hd. Phillips Mach. Screw	(1)
	47	Split Ring Lock Washer	(1)
	49	Power Cord w/Male Plug (Not Shown)	(1)
	50	Flat Washer	(1)
	51	Terminal Screw	(8)
	52	Service Nameplate (Not Shown)	(1)
	53	Warning Label (Not Shown)	(1)
	60	Cover Assembly	(1)
	61	Right Support Assembly	(1)
	62	Base	(1)
	63	Left Support Kit	(1)

**FIG. NOTES**  
52,53 A clean, dry surface is essential for proper performance for any adhesive system. The area intended for application of any adhesive label or nameplate must be prepared by cleing with isopropyl alcohol. The solvent is to be applied with a clean, lint free applicator and the surface allowed to dry before applying the label or nameplate.