

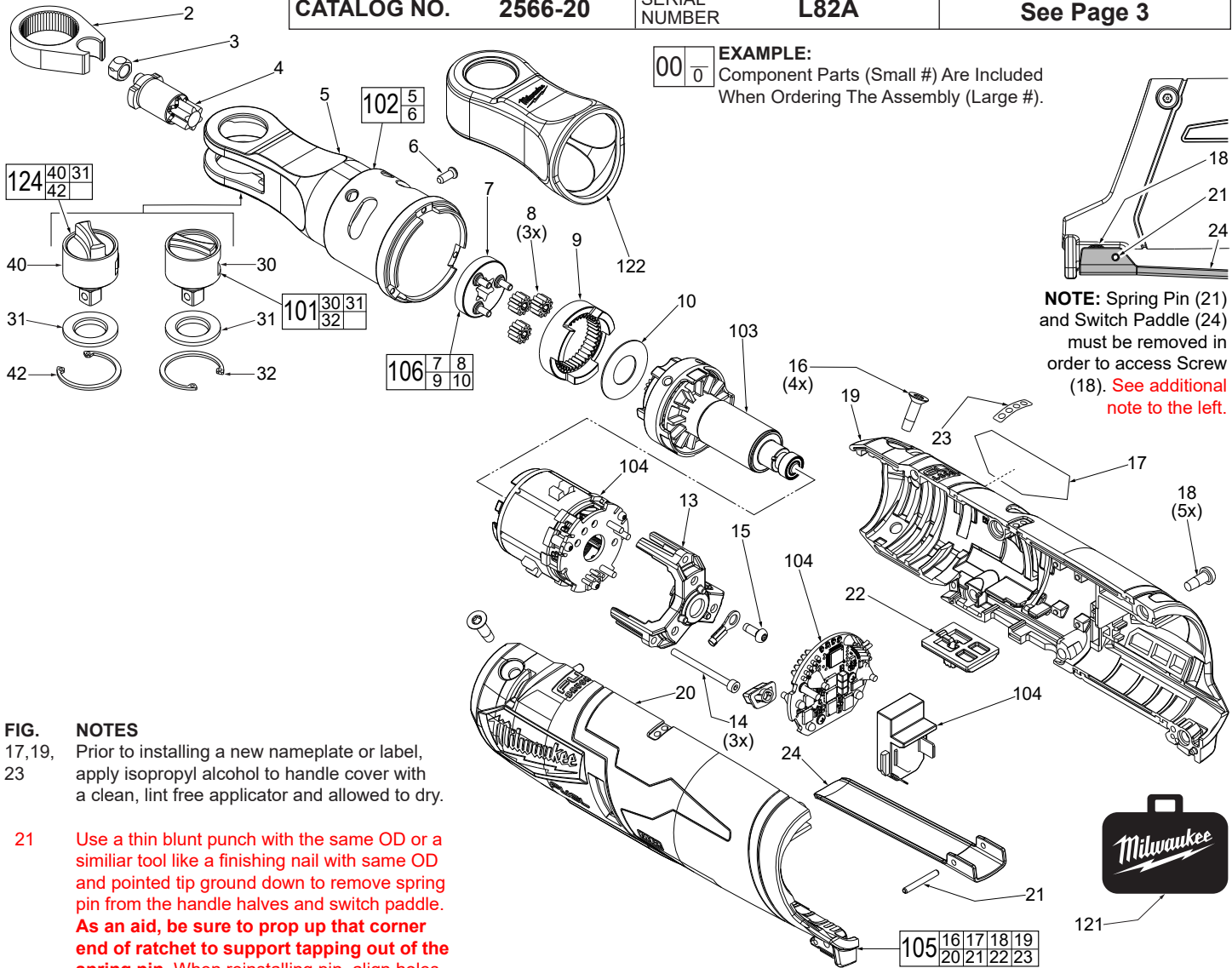

SERVICE PARTS LIST

BULLETIN NO.
54-47-2560

SPECIFY CATALOG NO. AND SERIAL NO. WHEN ORDERING PARTS		REVISED BULLETIN	DATE
M12™ FUEL 1/4" HIGH SPEED RATCHET			Oct. 2020
CATALOG NO.	2566-20	SERIAL NUMBER	L82A
			WIRING INSTRUCTION See Page 3



EXAMPLE:

00	0
----	---

 Component Parts (Small #) Are Included When Ordering The Assembly (Large #).

NOTE: Spring Pin (21) and Switch Paddle (24) must be removed in order to access Screw (18). See additional note to the left.

- FIG. 17, 19, 23** **NOTES**
 Prior to installing a new nameplate or label, apply isopropyl alcohol to handle cover with a clean, lint free applicator and allowed to dry.
- 21** Use a thin blunt punch with the same OD or a similar tool like a finishing nail with same OD and pointed tip ground down to remove spring pin from the handle halves and switch paddle. **As an aid, be sure to prop up that corner end of ratchet to support tapping out of the spring pin.** When reinstalling pin, align holes and carefully press or tap the pin in place.

FIG.	PART NO.	DESCRIPTION OF PART	NO. REQ.	FIG.	PART NO.	DESCRIPTION OF PART	NO. REQ.
2	45-98-0020	Yoke	(1)	32	-----	Retaining Ring	(1)
3	42-40-0017	Bushing	(1)	40	-----	1/4" Anvil w/ Tall Shift Knob (Optional)	(1)
4	36-17-0111	Crankshaft	(1)	42	-----	Retaining Ring	(1)
5	-----	Yoke Housing with Needle Bearings	(1)	101	42-06-0139	1/4" Anvil Service Kit-Standard	(1)
6	44-60-0890	Drive Pin	(1)	102	14-46-2560	Yoke Housing Service Kit	(1)
7	-----	Carrier	(1)	103	16-01-2560	Rotor Service Assembly	(1)
8	-----	Planetary Gears	(3)	104	14-20-2560	Electronics Service Assembly	(1)
9	-----	Ring Gear	(1)	105	31-44-2560	Housing Service Kit	(1)
10	-----	Washer	(1)	106	28-23-2500	Gear Set Service Kit	(1)
13	44-66-1006	Motor Plate	(1)	121	42-55-2561	Contractor Bag (Optional, Accessory)	(1)
14	05-84-0205	M2.5 x 31mm Skt. Hd. Hex Drive Screw	(3)	122	49-16-2567	Rubber Boot (Optional, Accessory)	(1)
15	06-82-2310	M3 x 8mm Pan Hd. Taptite T-10 Screw	(1)	124	49-06-2566	1/4" Anvil Service Kit-Tall (Optional, Accy.)	(1)
16	05-81-0594	M4 x 14mm Flat Hd. ST T-20 Screw	(4)				
17	12-20-2513	Service Nameplate	(1)				
18	05-71-0017	M4 x 10mm Pan Hd. ST T-20 Screw	(5)				
19	-----	Right Housing Halve - Cover	(1)				
20	-----	Left Housing Halve - Support	(1)				
21	44-60-0575	Spring Pin	(1)				
22	42-42-0119	Switch Lock-Out	(1)				
23	10-20-4419	Fuel Gauge Label	(1)				
24	44-10-0740	Switch Paddle	(1)				
30	-----	1/4" Anvil w/ Standard Shift Knob	(1)				
31	-----	Friction Plate	(1)				

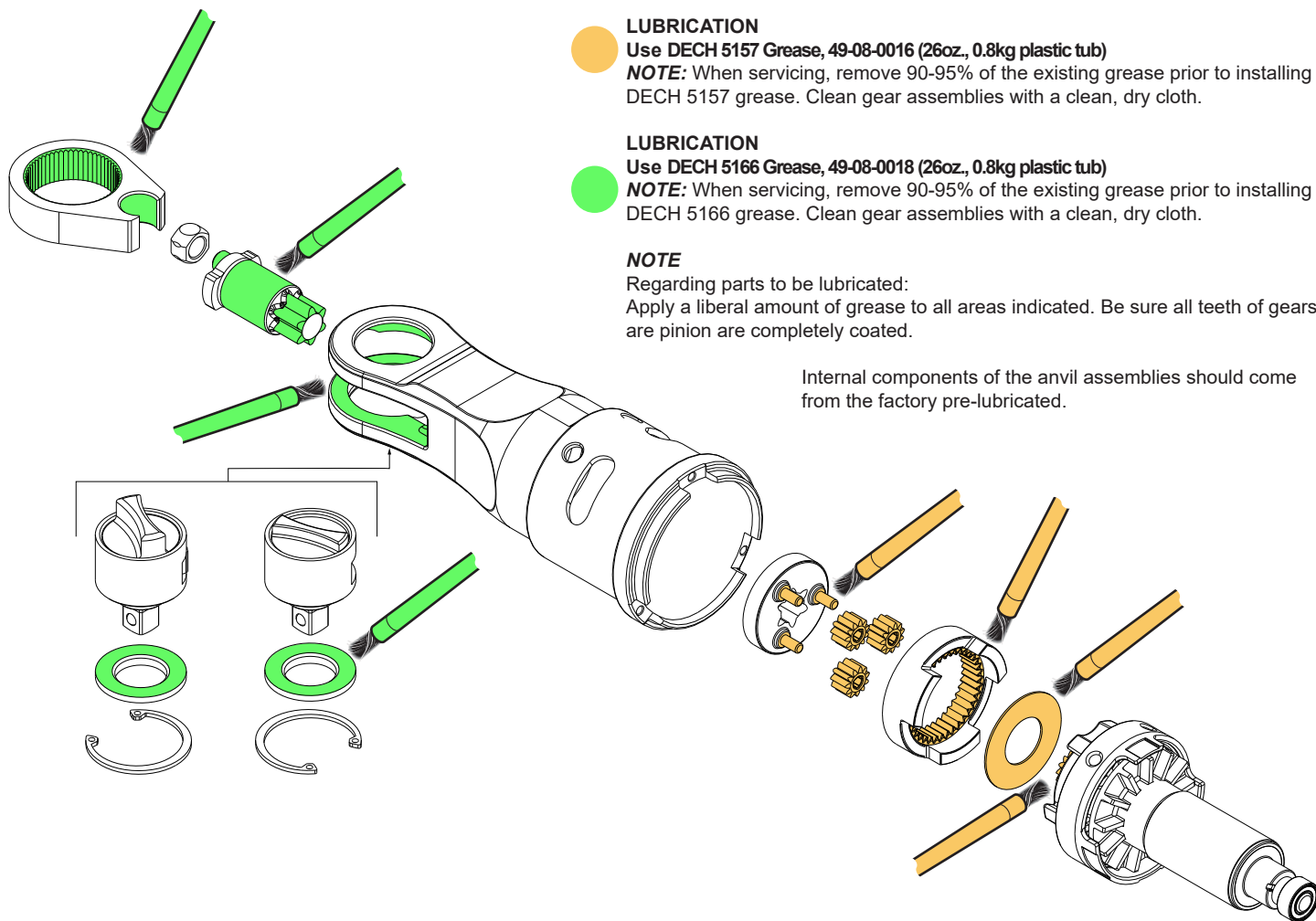

LUBRICATION
 Use DECH 5157 Grease, 49-08-0016 (26oz., 0.8kg plastic tub)
NOTE: When servicing, remove 90-95% of the existing grease prior to installing DECH 5157 grease. Clean gear assemblies with a clean, dry cloth.

LUBRICATION
 Use DECH 5166 Grease, 49-08-0018 (26oz., 0.8kg plastic tub)
NOTE: When servicing, remove 90-95% of the existing grease prior to installing DECH 5166 grease. Clean gear assemblies with a clean, dry cloth.

NOTE
 Regarding parts to be lubricated:
 Apply a liberal amount of grease to all areas indicated. Be sure all teeth of gears are pinion are completely coated.

Internal components of the anvil assemblies should come from the factory pre-lubricated.

SCREW TORQUE SPECIFICATIONS

FIG.	PART NO.	WHERE USED	SEAT TORQUE	
			(KG/CM)	(IN/LBS)
14	05-84-0205	Motor Plate	5-7	4-6
15	06-82-2310	HV Terminal/Motor Plate	12-14	10-12
16	05-81-0594	Housing Cover	14-16	12-14
18	05-71-0017	Housing Cover/Support	10-12	8-10

