



SERVICE PARTS LIST

**BULLETIN NO.
54-QC-2823**

SPECIFY CATALOG NO. AND SERIAL NO. WHEN ORDERING PARTS		REVISED BULLETIN	DATE
M18 FUEL™ 21" Self-Propelled Dual Battery Mower			Apr. 2022
CATALOG NO. 2823-20	STARTING SERIAL NO. M44A	WIRING INSTRUCTION See Pages 6, 7 & 8	

EXAMPLE:
 00 0 Component Parts (Small #) Are Included
 When Ordering The Assembly (Large #).

FRONT WHEELS / DECK	PAGE 2
REAR WHEELS / DECK	PAGE 3
HANDLE BAR / CONTROLS	PAGE 4
SCREW TORQUE CHART / SVC NOTES	PAGE 5
WIRING INSTRUCTIONS	PAGES 6,7,8
CONNECTOR HOT MELT PROCEDURE	PAGE 9

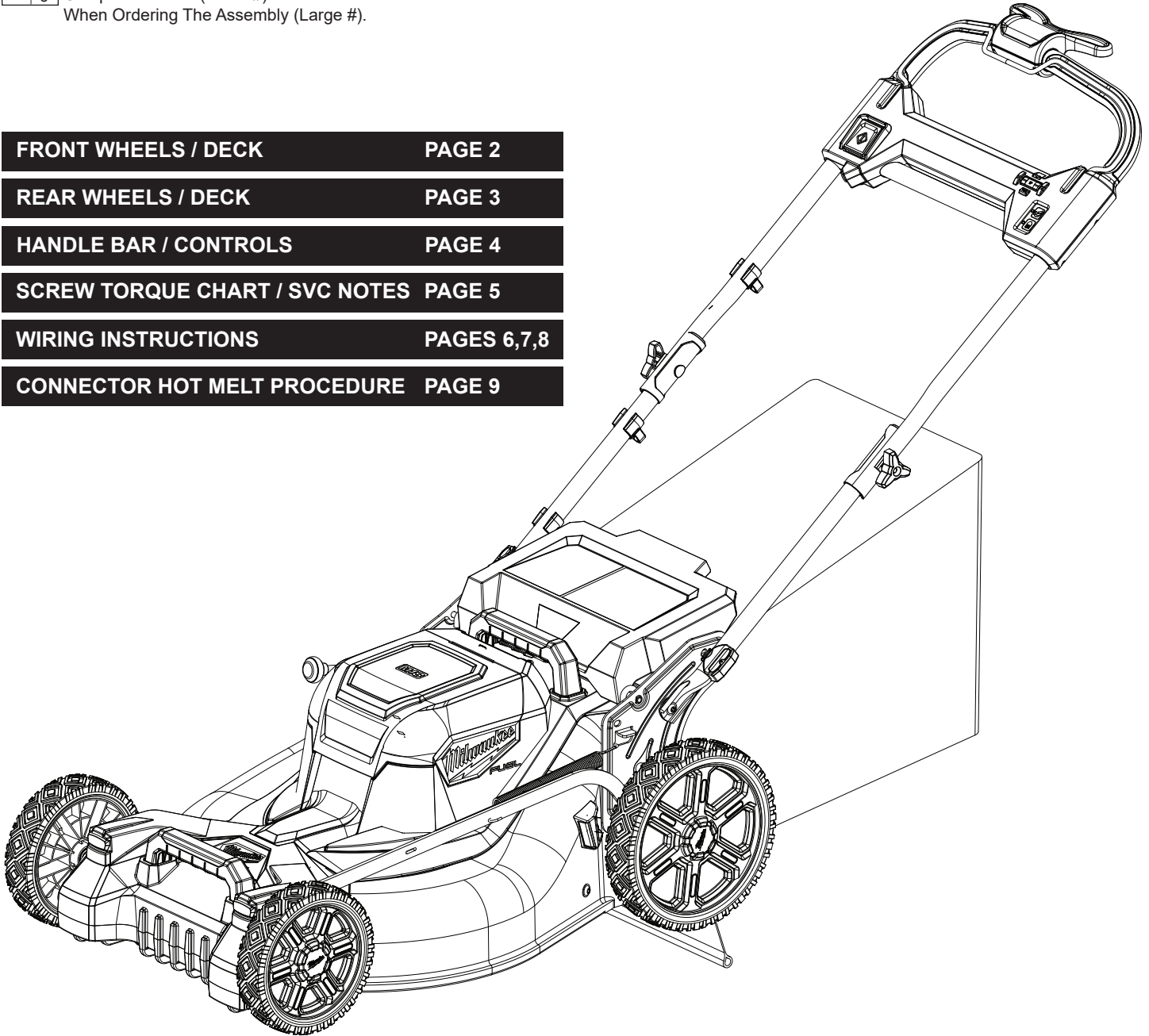

Service for this Milwaukee Tool FUEL Product
 Please Call: 1-833-953-2010

210	1	2b	3	4	9
	10	11	13	14	15
	16	17	18	144	147

205	2b	2c	5	6
	7	27	42	130

206	2c	12	20
	22	27	

204	2b	23	24	27
	28	29	38	53

200	2b	8	30	35b	43
	44	45	46	79	108

207	26	50
	51	52

202	47	48
	49	

201	2b	18b	21c	25	28
	29	31	32	33	39
	42	128			

203	28	29	36	61
	110b	139		

209	54	55	56
	57	58	59

FIG.	PART NO.	DESCRIPTION OF PART	NO. REQ.
1		Battery Power Head Cover	(1)
2b	06-82-1076	M4 x 16mm Pan Hd. Tapitite T-20 Screw	(27)
2c	06-82-1076	M4 x 16mm Pan Hd. Tapitite T-20 Screw	(8)
3		Rubber Bumper	(2)
4		Power Head Housing	(1)
5		Battery Interface - Left	(1)
6		Battery Interface - Middle	(1)
7		Battery Interface - Right	(1)
8		Back Mower Housing	(1)
9		Power Cable Strain Relief	(1)
10		Top Cover Torsion Spring	(1)
11		Top Cover Hinge Pin	(1)
12		Flat Washer	(2)
13		Fuel Power Lens	(1)
14		Lens Plate	(1)
15		Fuel Gauge PCBA	(1)
16		M3 Pan Washer Hd. ST Phillips Screw	(2)
17		Hinge Containment Tab	(2)
18	05-81-1195	M3 x 8mm Pan Hd. SP T-10 Screw	(8)
19		Rear Deck Lift Handle	(1)
20		Boat Securing Bracket	(1)
21c	05-81-0005	M3 x 11mm Pan Hd. Tapitite T-10 Screw	(4)
22		Main PCBA	(1)
23		Front Deck Lift Handle	(1)
24		Front Mower Housing	(1)
25		Headlight Assembly	(1)
26		Front Shaft Mount	(2)
27		M4 x 10mm Pan Hd. ST T-20 Screw	(5)
28		3/16" Wire Clip	(15)

FIG.	PART NO.	DESCRIPTION OF PART	NO. REQ.
29		M3 x 10mm Pan Washer Hd. ST T-10 Sc.	(15)
30		Motor	(1)
31	05-55-0022	M5 Hex Nut with Nylon Insert	(4)
32		Sidelight Assembly-Left	(1)
33		Right Sidelight Housing	(1)
34		Height Adjustment Backstop	(1)
36		M8 Square Nut	(1)
37		Rear Guard	(1)
38	05-74-0246	M6 x 16mm Pan Hd. T-30 Mach. Screw	(7)
39		Left Sidelight Housing	(1)
41	05-78-0032	M5 x 13mm Pan Hd. T-25 Mach. Screw	(4)
42		Wire Cover	(1)
43		Mower Deck	(1)
44		Blade Motor Housing	(1)
45		Flat Washer	(4)
46	05-74-0242	M6 x 25mm Pan Hd. T-30 Mach. Screw	(4)
47		Plastic Wheel Cap	(2)
48	05-55-0158	M10 Hex Nut with Nylon Insert	(2)
49		Front Wheel	(2)

FIG.	PART NO.	DESCRIPTION OF PART	NO. REQ.
50		Front Axle Weldment	(1)
51		Front Axle Mount Plate	(2)
52	05-74-0243	M5 x 44mm TH T-25 Machine Screw	(4)
53		Front Deck Baffle	(1)
54		Fan Spacer	(1)
55		Blade Motor Fan	(1)
56		21" Lawn Mower Blade	(1)
57		Shear Plate	(1)
58		Blade Washer	(1)
59		M12 Flange Nut	(1)
61		Rear Discharge Baffle	(1)
110b	05-74-0244	M8 x 20mm BUWH Hex Recess Screw	(3)
128		Sidelight Assembly-Right	(1)
130		Cord Clamp	(1)
139	05-74-0245	M6 x 10mm Pan Hd. Hex Recess Mach.	(1)
142		Rear Guard Plate	(1)
144		Fuel Gauge Decal	(1)
147		2 Battery Decal	(1)
200		Mower Chassis and Motor Assembly	(1)
201		LED Worklight Assemblies	(1)
202	28-41-0033	Front Wheel Assembly (Set of One)	(2)
203		Baffle Assembly	(1)
204		Front Housing Assembly	(1)
205		Battery Rail Assembly	(1)
206		Main PCBA Service Kit	(1)
207		Front Axle Service Kit	(1)
208	28-41-0018	Rear Guard Service Kit	(1)
209		Blade/Motor Fan Service Kit	(1)
210		Power Head Cover Assembly	(1)

FIG.	PART NO.	DESCRIPTION OF PART	NO. REQ.
35b	05-74-0241	M8 x 16mm Pan Hd. T-40 Mach. Screw	(10)
40	-----	Deck Height Adjustment Spring	(1)
43	-----	Mower Deck	(1)
47	45-94-0084	Plastic Wheel Cap	(2)
48	05-55-0158	M10 Hex Nut with Nylon Insert	(2)
60	-----	Height Adjustment Linkage Weldment	(1)
62	-----	Rear Wheel Assembly	(2)
63	-----	Wheel Gear	(2)
64a	05-78-5311	M5 x 18mm Pan Hd. Plast. T-20 Screw	(6)
65	-----	Retaining Ring	(2)
66	-----	Transmission Shaft Pinion	(2)
67	05-81-0266	M4 x 8mm Pan Hd. T-20 Mach. Screw	(2)
68	-----	Rear Wheel Drive Cover	(2)
69	-----	Height Adjustment Handle	(1)

70	-----	Deck Height Adjustment Torsion Spring	(1)
71	-----	Cotter Pin	(1)
72	-----	Rear Axle Weldment	(1)
73	-----	E-Retaining Ring	(4)
74	-----	Rear Bagger Door Hanging Rod	(1)
75	-----	Rear Door Torsion Spring	(1)
76	-----	Rear Bagger Door	(1)

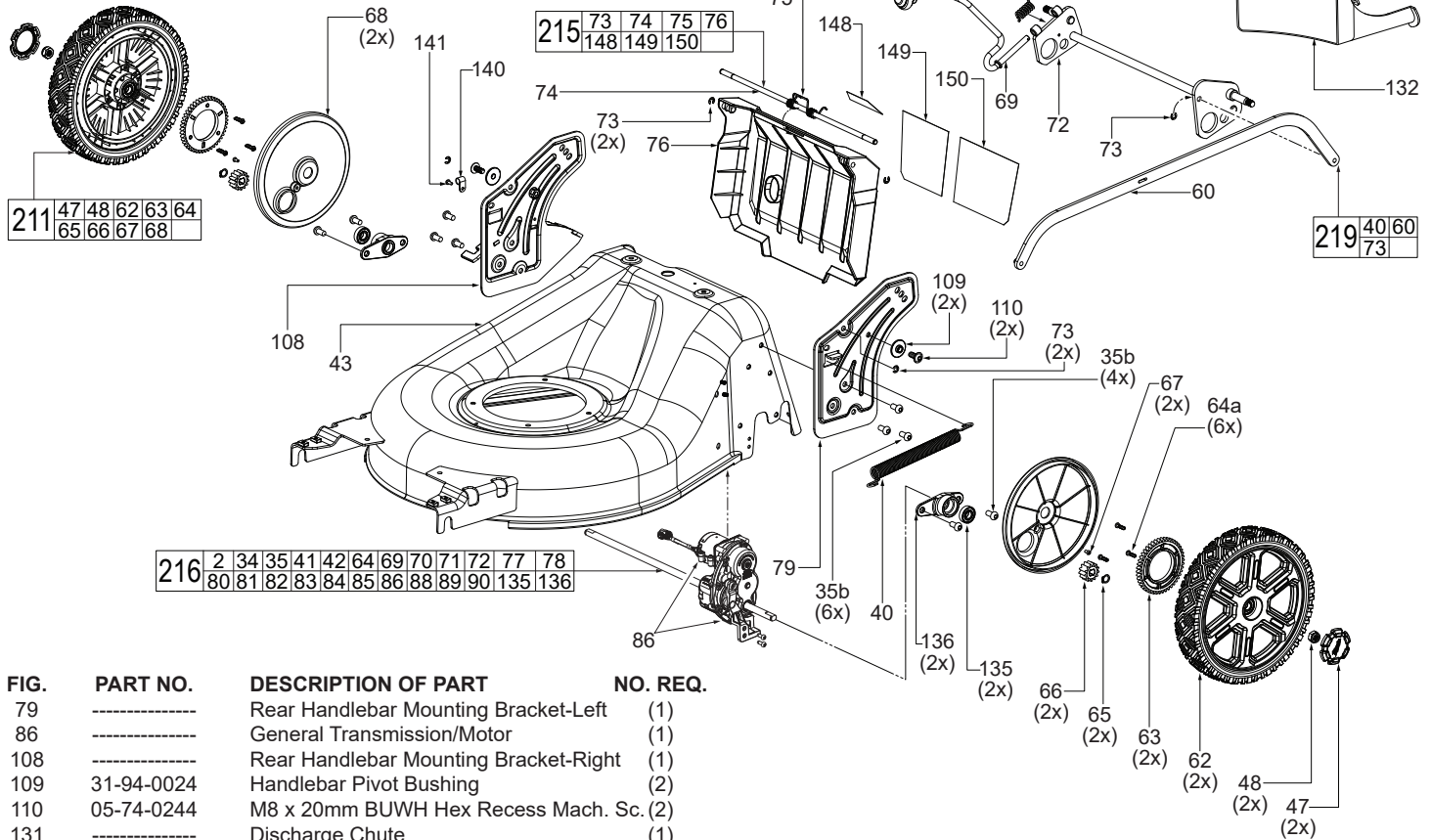
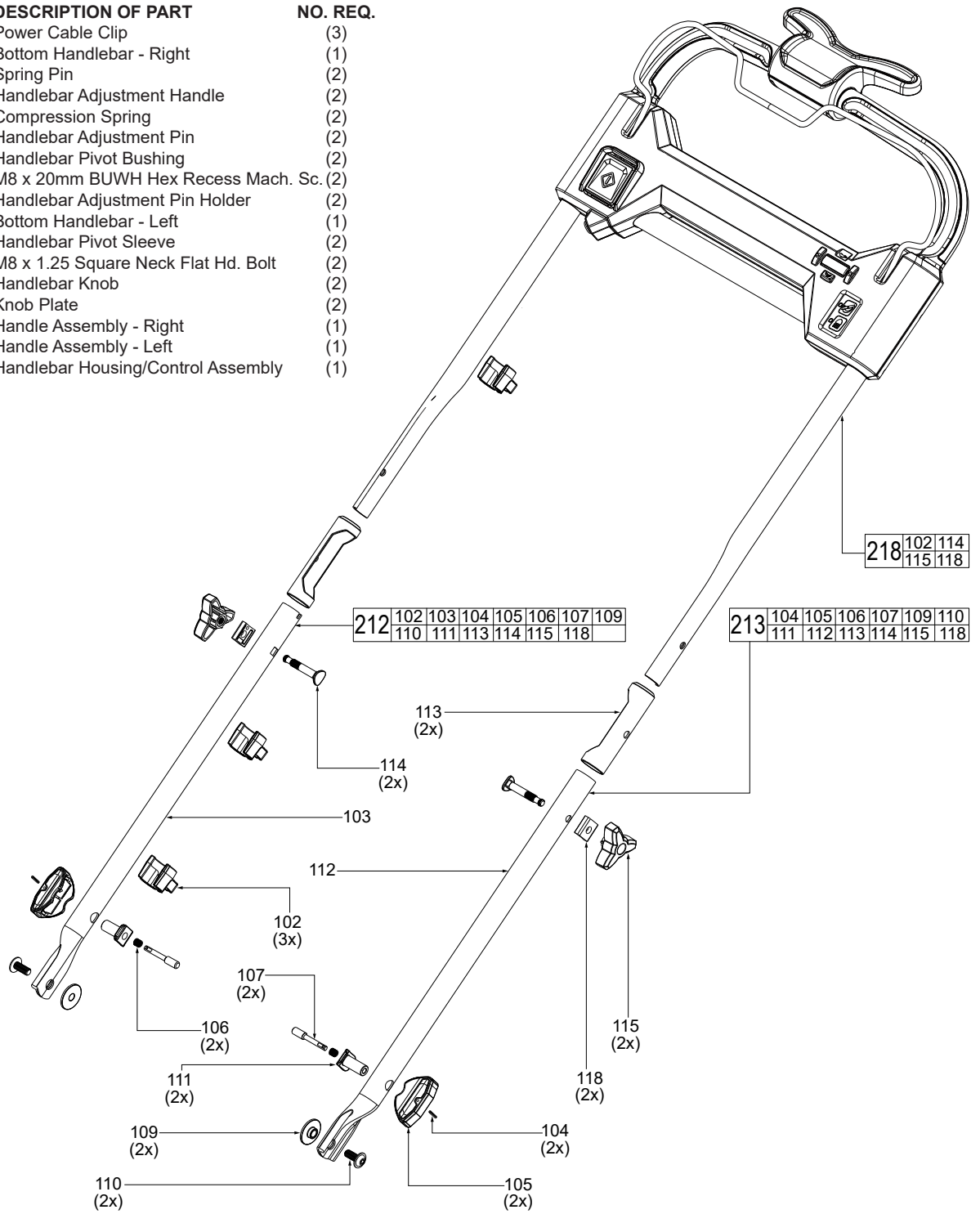

FIG.	PART NO.	DESCRIPTION OF PART	NO. REQ.
79	-----	Rear Handlebar Mounting Bracket-Left	(1)
86	-----	General Transmission/Motor	(1)
108	-----	Rear Handlebar Mounting Bracket-Right	(1)
109	31-94-0024	Handlebar Pivot Bushing	(2)
110	05-74-0244	M8 x 20mm BUWH Hex Recess Mach. Sc.	(2)
131	-----	Discharge Chute	(1)
132	-----	Mower Mulch Plug	(1)
133	28-20-0212	Rear Discharge Bagger Assembly	(1)
134	-----	Bagger Frame Weldment	(1)
135	-----	Ball Bearing	(2)
136	-----	Rear Wheel Drive Hub	(2)
140	-----	3/8" Wire Clip	(1)
141	05-81-1030	M4 x 9mm Pan Hd. T-20 Machine Screw	(1)
148	-----	Service Nameplate	(1)
149	-----	Warning and Safety Decal-Right	(1)
150	-----	Warning and Safety Decal-Left	(1)
211	28-50-0023	Rear Wheel Assembly (Set of One)	(2)
214	14-46-0194	Bagger Assembly	(1)
215	-----	Rear Bagger Door Assembly	(1)
216	-----	Transmission and Motor Assembly	(1)
217	31-15-0069	Chute Service Kit	(1)
219	-----	Linkage/Spring Service Kit	(1)

FIG.	PART NO.	DESCRIPTION OF PART	NO. REQ.
102	22-44-0010	Power Cable Clip	(3)
103	-----	Bottom Handlebar - Right	(1)
104	-----	Spring Pin	(2)
105	-----	Handlebar Adjustment Handle	(2)
106	-----	Compression Spring	(2)
107	-----	Handlebar Adjustment Pin	(2)
109	31-94-0024	Handlebar Pivot Bushing	(2)
110	05-74-0244	M8 x 20mm BUWH Hex Recess Mach. Sc.	(2)
111	-----	Handlebar Adjustment Pin Holder	(2)
112	-----	Bottom Handlebar - Left	(1)
113	31-44-0174	Handlebar Pivot Sleeve	(2)
114	05-74-0102	M8 x 1.25 Square Neck Flat Hd. Bolt	(2)
115	43-98-0307	Handlebar Knob	(2)
118	45-88-0279	Knob Plate	(2)
212	-----	Handle Assembly - Right	(1)
213	-----	Handle Assembly - Left	(1)
218	-----	Handlebar Housing/Control Assembly	(1)



SCREW TORQUE SPECIFICATIONS

FIG.	PART NO.	DESCRIPTION OF FASTENER	WHERE USED	SEAT TORQUE	
				(KG/CM)	(IN/LBS)
2b	-----	M4 x 16mm Pan Hd. Taptite T-20 Screw	Front Deck Baffle	14±1.5	12.15±1.3
2b	-----	M4 x 16mm Pan Hd. Taptite T-20 Screw	Wire Cover	14±1.5	12.15±1.3
2b	-----	M4 x 16mm Pan Hd. Taptite T-20 Screw	Power Head Housing	14±1.5	12.15±1.3
2b	-----	M4 x 16mm Pan Hd. Taptite T-20 Screw	Battery Interface - Left, Left & Middle	14±1.5	12.15±1.3
2b	-----	M4 x 16mm Pan Hd. Taptite T-20 Screw	Cord Clamp	14±1.5	12.15±1.3
2b	-----	M4 x 16mm Pan Hd. Taptite T-20 Screw	Blade Mower Housing	14±1.5	12.15±1.3
2c	-----	M4 x 16mm Pan Hd. Taptite T-20 Screw	Boat Securing Bracket	14±1.5	12.15±1.3
2c	-----	M4 x 16mm Pan Hd. Taptite T-20 Screw	Battery Interface - Left and Right	14±1.5	12.15±1.3
16	06-82-0276	M3 Pan Washer Hd. ST Phillips Screw	Fuel Gauge PCBA	4.0±1	3.47±0.86
18	05-81-1195	M3 x 8mm Pan Hd. SP T-10 Screw	Light Head Assembly	4.0±1	3.47±0.86
18	05-81-1195	M3 x 8mm Pan Hd. SP T-10 Screw	Hinge Containment Tab	3.0±.5	2.60±0.43
21c	05-81-0005	M3 x 11mm Pan Hd. Taptite T-10 Screw	Sidelight Assembly - Left and Right	5.0±1	4.33±0.86
27	-----	M4 x 10mm Pan Hd. ST T-20 Screw	Main PCBA	7.0±1	6.07±0.86
27	-----	M4 x 10mm Pan Hd. ST T-20 Screw	Back Mower Housing	14±1.5	12.15±1.3
29	-----	M3 x 10mm Pan Washer Hd. ST T-10 Sc.	Wire Clip	3.5±1	3.03±0.86
31	-----	M5 Hex Nut with Nylon Insert	Sidelight Housing - Left and Right	18±2	15.62±1.7
35b	05-74-0241	M8 x 16mm Pan Hd. T-40 Mach. Screw	Rear Handlebar Mounting Bracket - L & R	165±15	143±13.0
35b	05-74-0241	M8 x 16mm Pan Hd. T-40 Mach. Screw	Rear Wheel Drive Hub	165±15	143±13.0
38	05-74-0246	M6 x 16mm Pan Hd. T-30 Mach. Screw	Rear Guard and Mower Deck	30±3	26.03±2.6
41	-----	M5 x 13mm Pan Hd. T-25 Mach. Screw	Mower Deck	23±3	19.96±2.6
46	05-74-0242	M6 x 25mm Pan Hd. T-30 Mach. Screw	Blade Mower Housing	30±3	26.03±2.6
48	-----	M10 Hex Nut with Nylon Insert	Front Axle Weldment	180±10	156.2±8.67
48	-----	M10 Hex Nut with Nylon Insert	Rear Axle Weldment	180±10	156.2±8.67
52	05-74-0243	M5 x 44mm TH T-25 Machine Screw	Front Axle Mount Plate	18±2	15.62±1.7
*59	-----	Blade Flange Nut	Shear Plate/Blade Washer/Mower Blade	380±20	329±17
64a	-----	M5 x 18mm Pan Hd. Plast. T-20 Screw	Wheel Gear	16±1.5	13.88±1.3
67	-----	M4 x 8mm Pan Hd. T-20 Mach. Screw	Rear Wheel Gear Cover	10±1	8.67±0.86
110	05-74-0244	M8 x 20mm BUWH Hex Recess Mach. Sc.	Rear Handlebar Mounting Bracket - L & R	35±3.5	30.37±3.0
110b	05-74-0244	M8 x 20mm BUWH Hex Recess Screw	Rear Discharge Baffle	35±3.5	30.37±3.0
110b	05-74-0244	M8 x 20mm BUWH Hex Recess Screw	Mower Deck	165±15	143±13.0
139	05-74-0245	M6 x 10mm Pan Hd. Hex Recess Mach.	Rear Discharge Baffle	30±3	26.03±2.6
141	-----	M4 x 9mm Pan Hd. T-20 Machine Screw	Wire Clip	10±1	8.67±0.86

*Indicates Critical Torque

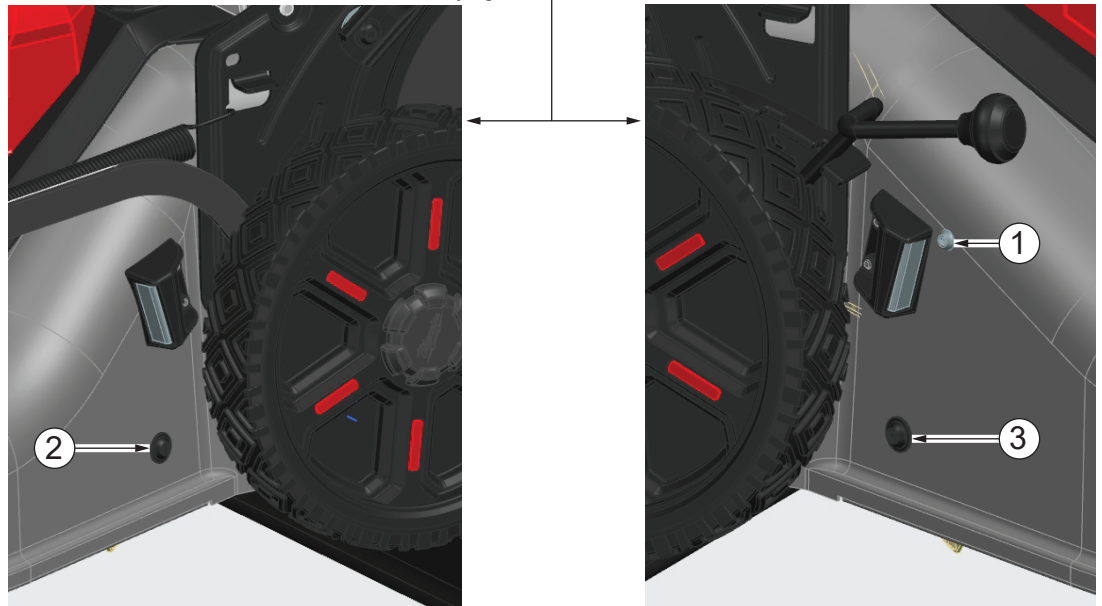
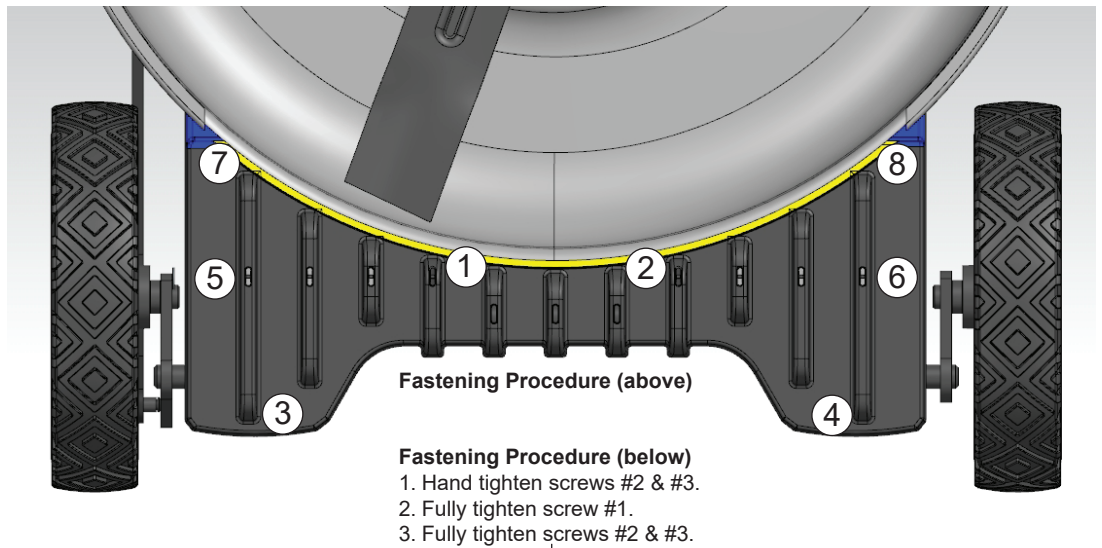

Wire Routing for Switch Cable

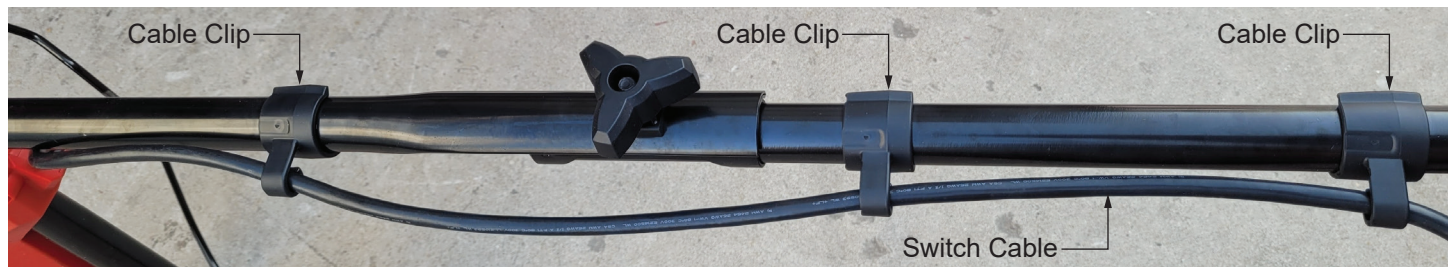

Secure the Switch Cable with three Cable Clips, as shown.

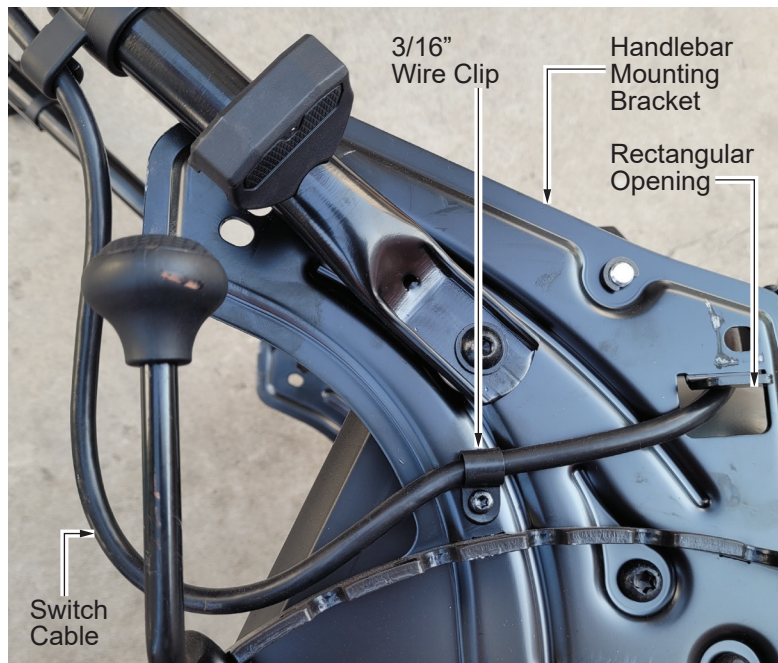

Secure the Switch Cable with Wire Clip as shown. Route Switch Cable through the rectangular opening of the Handlebar Mounting Bracket.

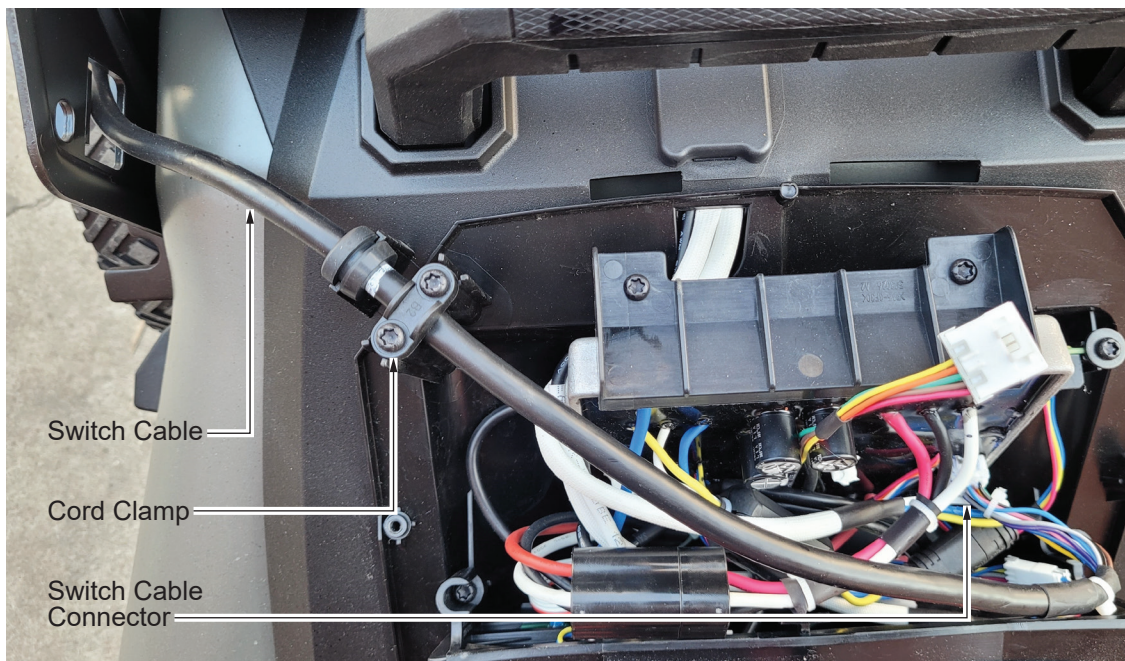

Plug the connector of the Switch Cable into connector from the Main PCBA. Secure Switch Cable with a Cord Clamp and two screws.

Wire Routing for Front LED Lights and Blade Motor

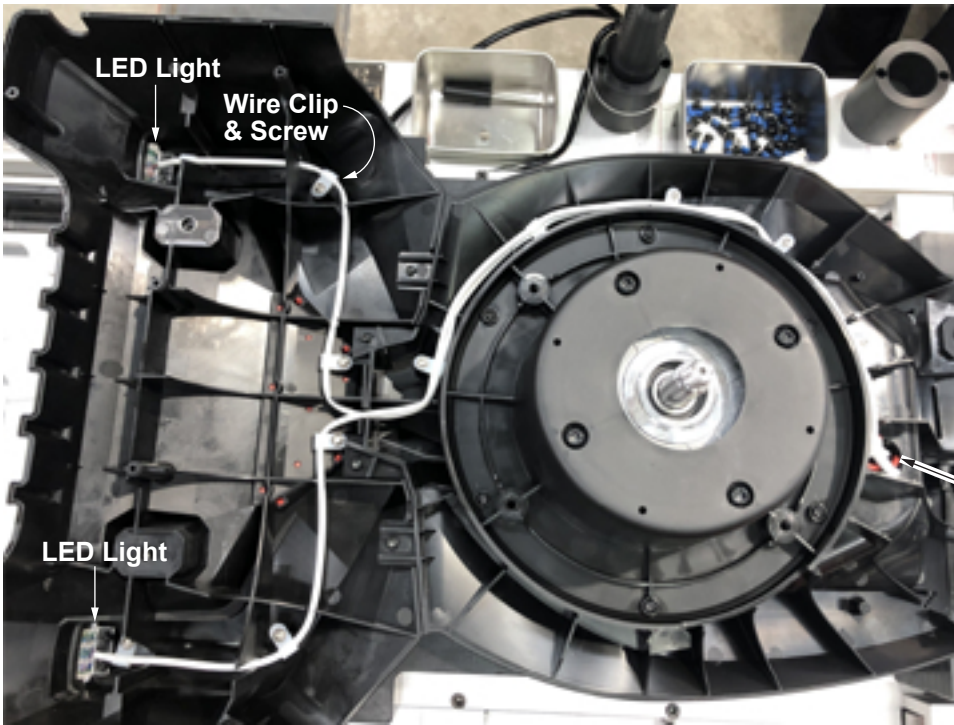

Route wires for the front LED lights as shown. Be sure to place wires completely in the bottom of all wire traps. Secure front LED light wires with 12 wire clips and screws.

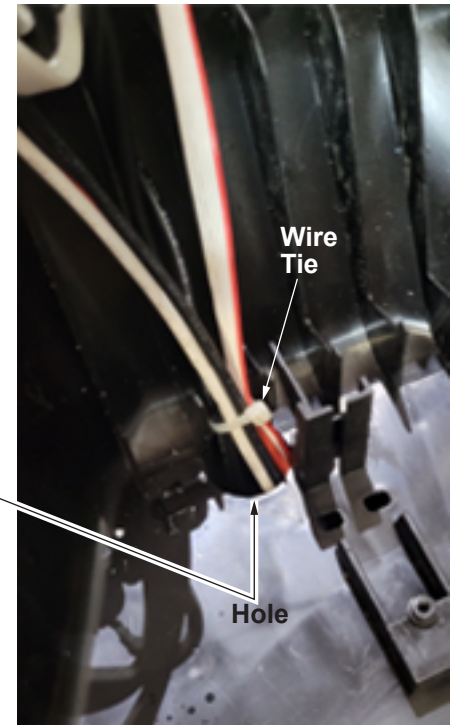

Route wires from front LED lights and blade motor through hole here. Fasten wires together with wire tie.

Wire Routing for Side Lights and Drive Motor



Route the wires for side LED lights and drive motor through hole here, with the left LED wire and the motor wire through the hole directly.

The right LED wire needs to cross the rear baffle then go through the hole.

Cross the wires through the plastic part and place the wires between PCBA plate and screw boss for securing bracket.

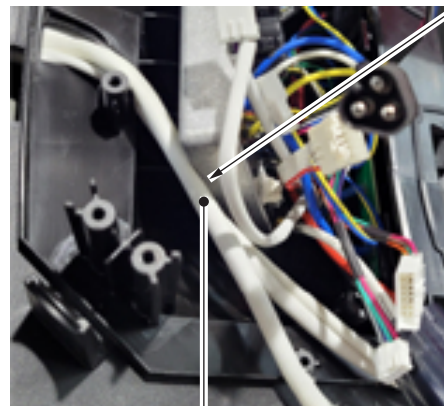
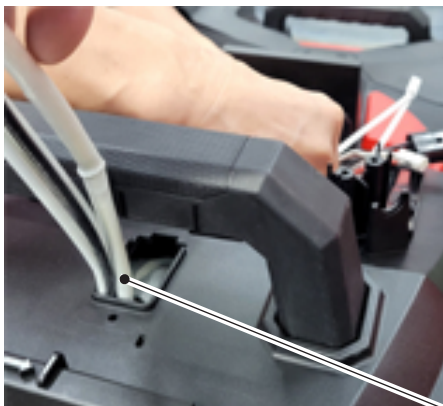

Wires for side lights and drive motor

Boat securing bracket

Wire Routing for Main PCBA

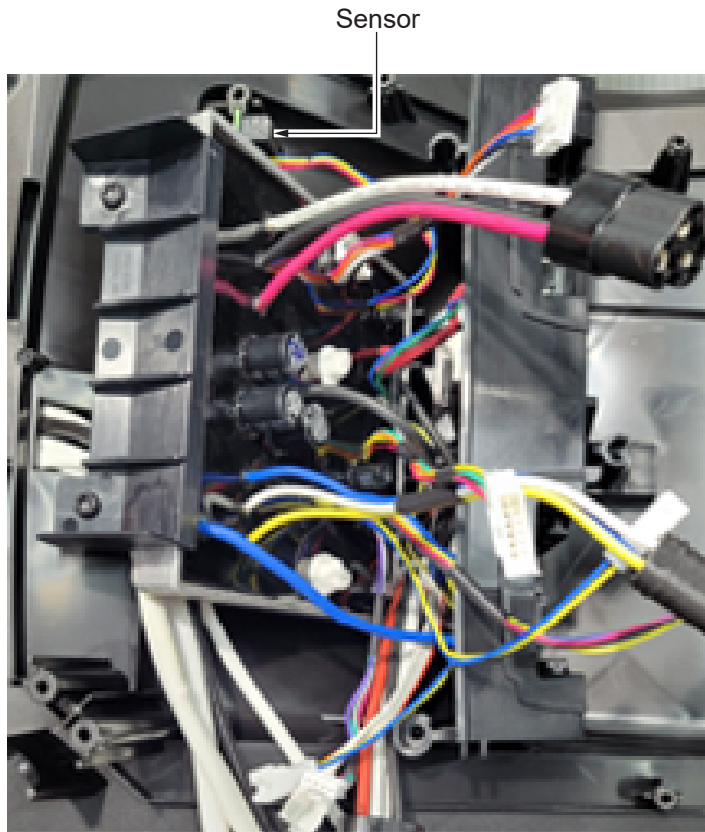

Before plugging connectors, orient and place the sensor in the area shown.

Place the connectors for the lights and motors on the side of the PCBA boat shown.

Plug connectors for lights and motors into the connectors from the PCBA in the order of the smallest to the largest.

There are two connectors left unplugged, one will be connected with the fuel gauge connector and the other will connect to the switch connector.

Join this Connector to the Fuel Gauge Connector

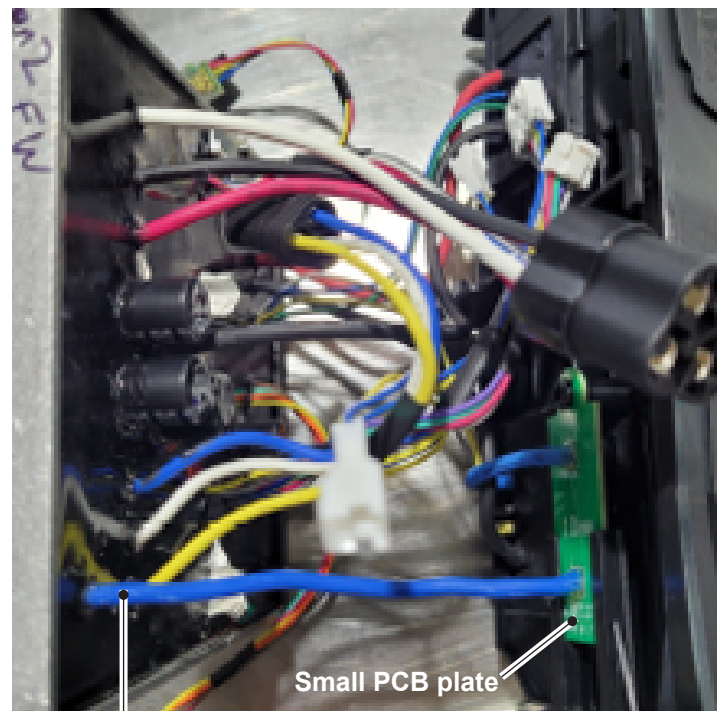

Make sure that no wire crosses over this blue wire when fastening the small PCB plate.

SEE NEXT PAGE FOR LUBRICATION AND HOT MELT GLUE APPLICATION PROCESSES RELATING TO THIS CONNECTOR

Join this Connector to the Switch Connector





PROCEDURAL OVERVIEW
Surface prep and glue

Equipment

1. Sure Bonder (PRO9700A)
Adjustable Temp Glue Gun
2. Element HMS707 (Hot Melt Glue)
3. Cleaning Pads
4. Isopropyl Alcohol
5. ESD Bracelet

Procedure

 ESD Protection must be worn in this station.

 1. Sure Bonder (PRO9700A)
Adjustable Temp Glue Gun Settings:
 • Temperature Setting is 320°F.
 • Trigger Pull is set to Full Stroke (Approx. 1").

2. Locate and Clean the connector location with an Isopropyl wipe. Remove excess Dielectric Grease.

3. Wipe Excessive Dielectric Grease off the connector on all 4 sides with an alcohol wipe.

- a. Take one wipe per mower
- b. Soak wipe with alcohol
- c. Use wipe to remove excess Dielectric Grease from 4 sides of connector
- d. Discard wipe after each mower

 4. Push Connector in with ~5lbf of force

 5. Visually inspect that connector is properly seated - check for connector damage

6. Use PRO9700A Glue Gun to Apply Hot Melt to harness and connector

 7. Apply 1st Trigger Stroke (~5 Seconds) starting at the wire harness and working in an arcing motion (back and forth) towards the base of the connector

8. Pause to allow for slight cure (~ Seconds)

 9. Apply 2nd Trigger Stroke (~ Seconds) repeating the process for Step 4

 a. **Work to encapsulate the entire connector with Hot Melt**

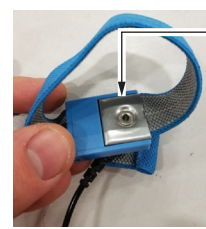
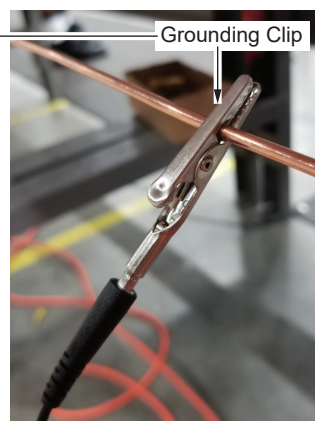
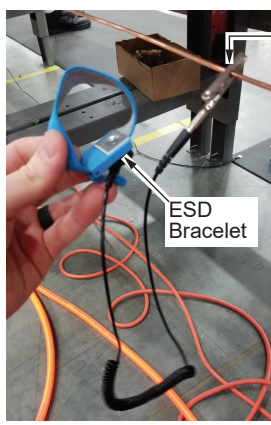
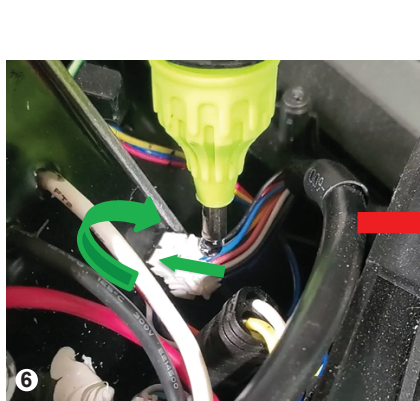

Technician must stand on mat.

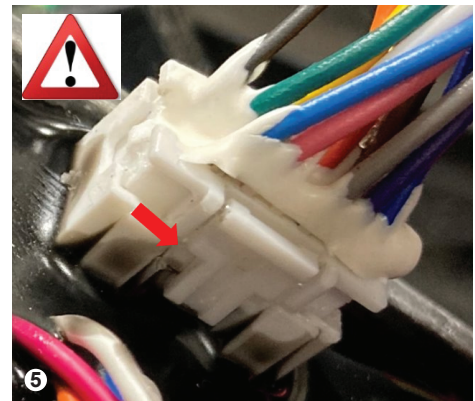
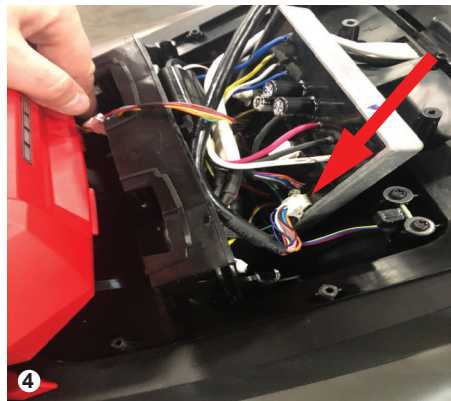
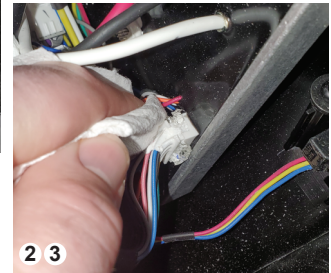
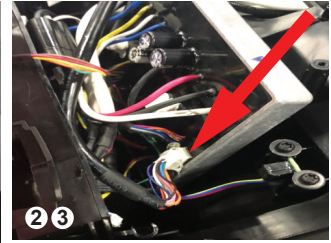
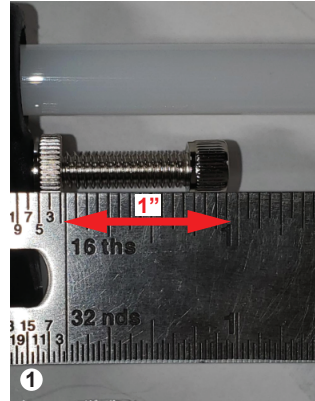

 10. Inspect Glue application after 30 Second Cure
 a. Ensure Connector and Harness are encased in Hot Melt

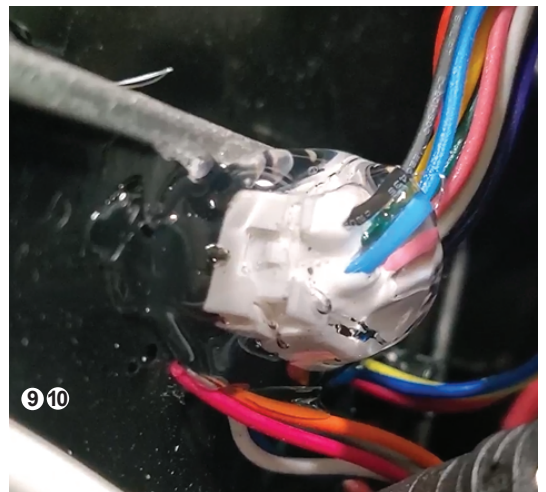

ATTENTION
 OBSERVE PRECAUTIONS
 FOR HANDLING
 ELECTROSTATIC
 SENSITIVE
 DEVICES