



SERVICE PARTS LIST

BULLETIN NO.
54-38-2152

SPECIFY CATALOG NO. AND SERIAL NO. WHEN ORDERING PARTS		REVISED BULLETIN 54-38-2151	DATE Sept. 2017
4.5" COMPACT RAT-TAIL ANGLE GRINDER with lock-on			
CAT. NO.	6121-30	STARTING SERIAL NUMBER C96C	WIRING INSTRUCTION See Reverse Side

FIG.	PART NO.	DESCRIPTION OF PART	NO. REQ.
★ 1	05-88-1650	M4 x 25mm Pan Hd. ST Screw T-20	(7)
2	42-62-0120	Side Handle Assembly	(1)
★ 3	14-30-1156	Gearcase Assembly	(1)
3g	02-04-0620	Ball Bearing	(1)
4	34-40-0560	O-Ring	(1)
★ 5	14-73-0460	5/8-11 Spindle Hub Kit	(1)
★ 5b	-----	Steel Pin	(1)
★ 5c	-----	Spring	(1)
★ 5d	44-20-0155	Guard Locking Tang	(1)
★ 5e	05-81-0020	M3 x 5mm Pan Hd. ST T-8 Screw	(1)

★ = Part number change from previous service parts list.

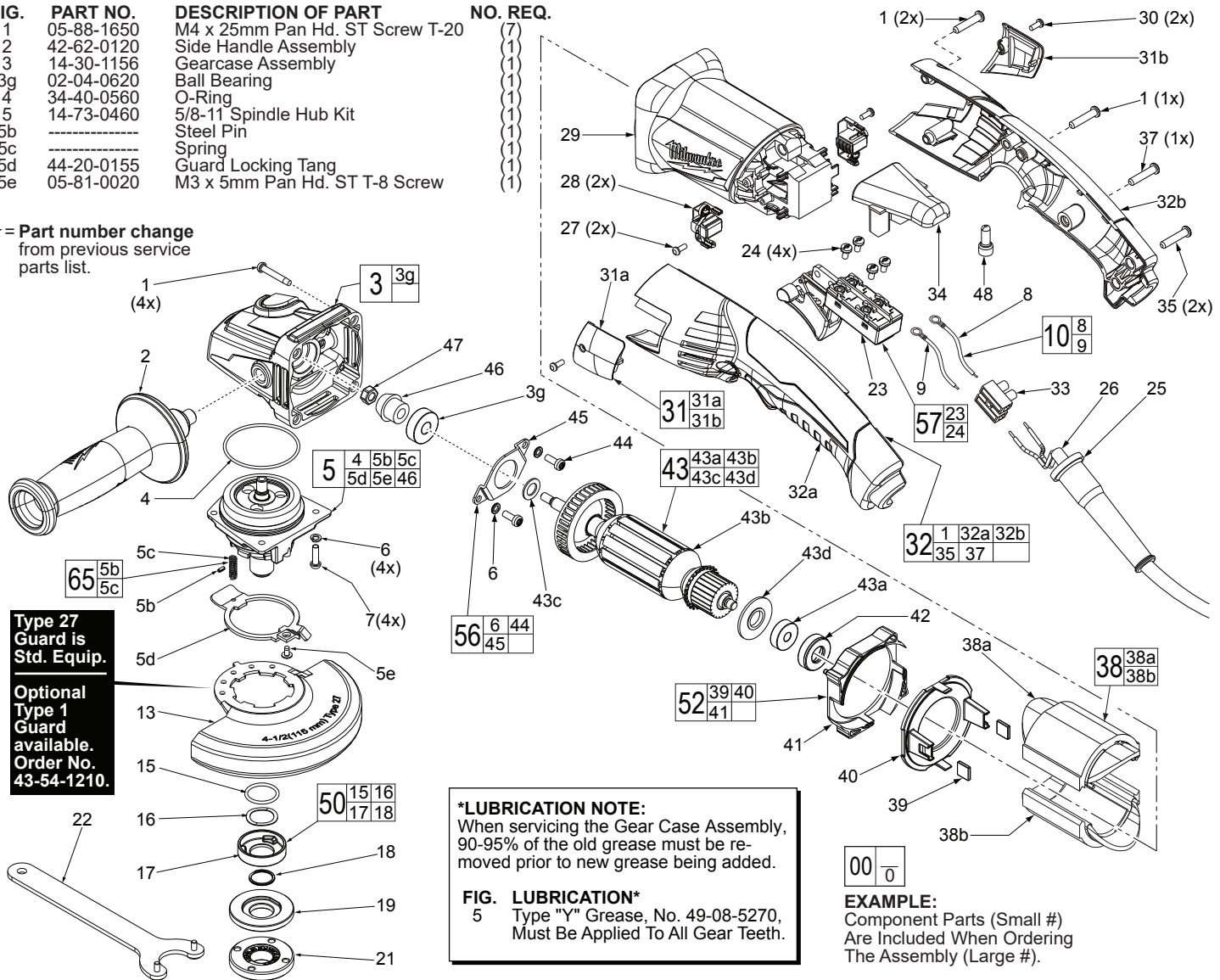

Type 27 Guard is Std. Equip.
Optional Type 1 Guard available. Order No. 43-54-1210.

***LUBRICATION NOTE:**
When servicing the Gear Case Assembly, 90-95% of the old grease must be removed prior to new grease being added.

FIG. LUBRICATION*
5 Type "Y" Grease, No. 49-08-5270, Must Be Applied To All Gear Teeth.

EXAMPLE:
Component Parts (Small #) Are Included When Ordering The Assembly (Large #).

FIG.	PART NO.	DESCRIPTION OF PART	NO. REQ.
6	05-90-0225	Spring Washer	(6)
7	05-78-5316	M4 x 14mm Pan Hd. Tapt. Screw T-20	(4)
8	-----	Leadwire - Black	(1)
9	-----	Leadwire - White	(1)
10	23-94-0345	Leadwire Assy. Kit	(1)
★ 13	43-54-1200	4.5" Type 27 Guard (Standard Equip.)	(1)
★ 13	43-54-1210	4.5" Type 1 Guard (Optional, Not Shown)	(1)
15	-----	O-Ring	(1)
16	-----	Wavey Spring	(1)
17	-----	Flange with Ramps	(1)
18	-----	Retaining Ring	(1)
19	43-34-0935	Inner Disc Flange	(1)
21	44-40-0035	Outer Flange Nut	(1)
★ 22	49-96-7215	Spanner Wrench	(1)
23	-----	Trigger Switch	(1)
24	05-78-0305	M3.5 x 7mm Pan Hd. Phil. Switch Scr.	(4)
25	44-76-0095	Cord Protector	(1)
26	22-64-3425	Power Cord	(1)
27	05-88-0030	M3 x 8.5mm Pan Hd. ST Screw T-10	(2)
28	22-18-2240	Carbon Brush Assembly (Set of 2)	(1)
29	31-50-0695	Motor Housing	(1)
30	06-82-2395	M2.6 x 10mm Pan Hd. ST Screw T-9	(2)
31	31-15-1005	Brush Cover Assembly (Set of 2)	(1)
31a	-----	Brush Cover - Left	(1)
31b	-----	Brush Cover - Right	(1)
32	14-34-6115	Rear Handle Set (For lock-on switch)	(1)
32a	-----	Handle Half - Left	(1)
32b	-----	Handle Half - Right	(1)
33	22-56-0475	Terminal Connector Block	(1)

FIG.	PART NO.	DESCRIPTION OF PART	NO. REQ.
34	22-09-1825	PCB Assembly	(1)
35	05-88-1255	M4 x 22mm Pan Hd. ST T-20	(2)
37	06-82-1020	M4 x 14mm Pan Hd. ST T-20	(1)
38	18-07-0285	Field Assembly	(1)
38a	-----	Field Halve	(1)
38b	-----	Field Halve	(1)
39	42-28-0085	Rubber Block	(2)
40	-----	Baffle Foot	(1)
41	-----	Baffle	(1)
42	42-96-0016	Rubber Bearing Cap	(1)
43	16-10-0850	Armature Assembly	(1)
43a	02-04-2110	Ball Bearing	(1)
43b	-----	Armature	(1)
43c	45-88-0406	Washer	(1)
43d	31-86-0090	Plastic Disc	(1)
44	05-78-0105	M4 x 10mm Pan Hd. Tapt. Screw T-20	(2)
45	44-86-0155	Bearing Retainer	(1)
★ 46	-----	Pinion	(1)
47	05-55-0620	M5 Hex Nut	(1)
48	22-56-0150	Close End Connector	(1)
50	14-46-6105	Flange with Ramps Assembly	(1)
52	42-14-0520	Baffle Assembly	(1)
56	44-86-0145	Bearing Retaining Plate Assembly	(1)
57	14-78-0550	Trigger Switch Assembly	(1)
★ 65	14-46-0241	Spring/Pin Kit	(1)

NOTE:
PCBA wire #10 can be routed to the lower right switch position or connect with white wire #4 in terminal block T1 as shown .

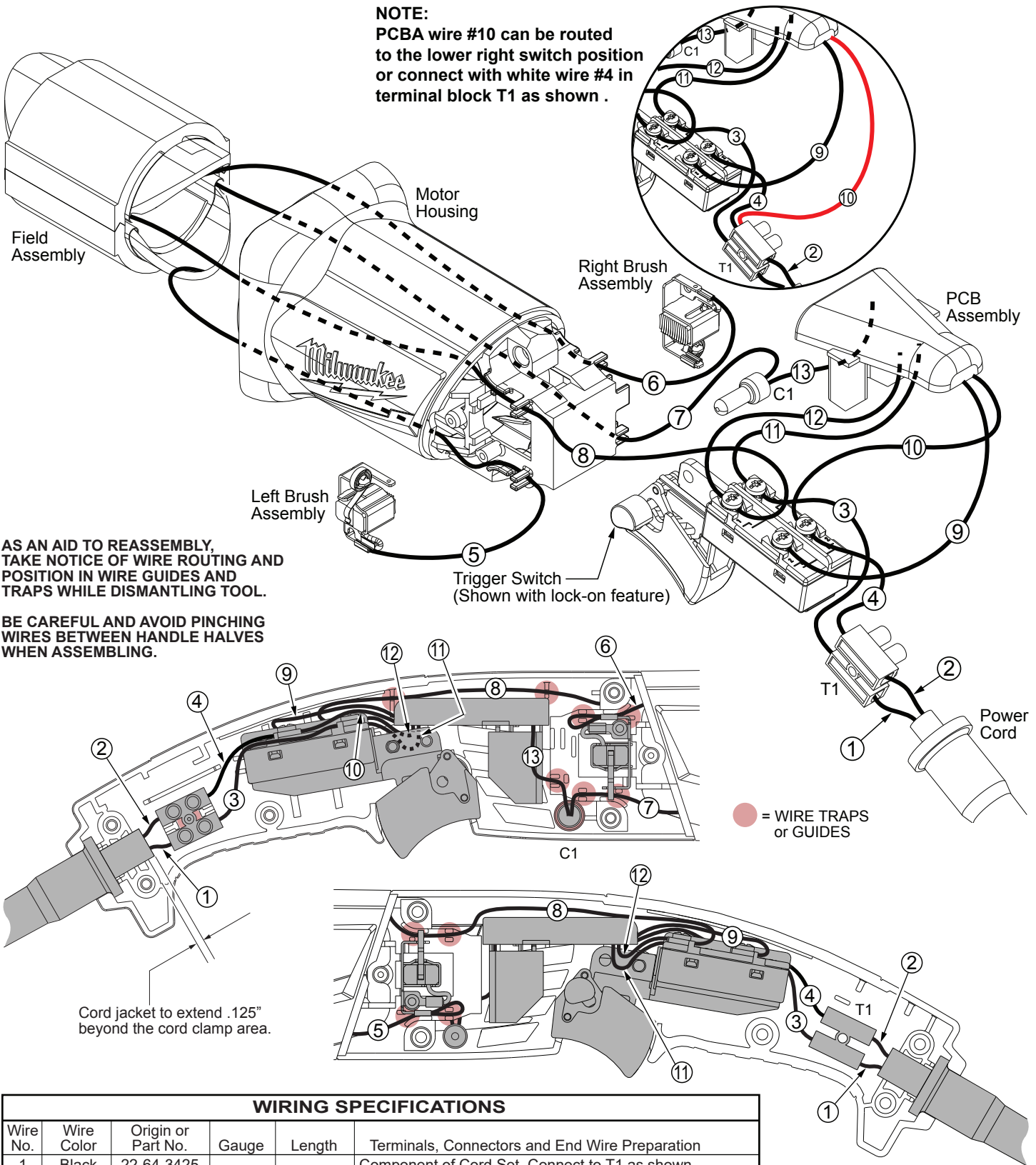

AS AN AID TO REASSEMBLY, TAKE NOTICE OF WIRE ROUTING AND POSITION IN WIRE GUIDES AND TRAPS WHILE DISMANTLING TOOL.

BE CAREFUL AND AVOID PINCHING WIRES BETWEEN HANDLE HALVES WHEN ASSEMBLING.

● = WIRE TRAPS or GUIDES

WIRING SPECIFICATIONS

Wire No.	Wire Color	Origin or Part No.	Gauge	Length	Terminals, Connectors and End Wire Preparation
1	Black	22-64-3425	--	--	Component of Cord Set. Connect to T1 as shown.
2	White	22-64-3425	--	--	Component of Cord Set. Connect to T1 as shown.
3	Black	23-94-0345	--	--	Comp. of Leadwire Assembly Kit. Connect to Switch and T1 as shown.
4	White	23-94-0345	--	--	Comp. of Leadwire Assembly Kit. Connect to Switch and T1 as shown.
5	Black	18-07-0285	--	--	Comp. of Field. Connect to Left Brush Assy. as shown.
6	Black	18-07-0285	--	--	Comp. of Field. Connect to Right Brush Assy. as shown.
7	Black	18-07-0285	--	--	Comp. of Field. Connect to Wire #13 with C1 as shown.
8	Black	18-07-0285	--	--	Component of Field. Connect to Switch as shown.
9	White	22-09-1825	--	--	Comp. of PCB Assembly. Connect to Switch as shown.
10	White	22-09-1825	--	--	Comp. of PCB Assy. Connect to Switch or T1 as shown.
11	Black	22-09-1825	--	--	Comp. of PCB Assembly. Connect to Switch as shown.
12	Blue	22-09-1825	--	--	Comp. of PCB Assembly. Connect to Switch as shown.
13	Red	22-09-1825	--	--	Comp. of PCB Assembly. Connect to Wire #7 with C1.

BULK LEAD WIRE - BULLETIN 58-01-0003

NOTE:
All leads must be held to ± 1/16".
All lead lengths are before stripping.

TERMINAL DESCRIPTION		
Code	Part No.	Qty.
T1	22-56-0475	1
CONNECTOR DESCRIPTION		
C1	22-56-0150	1