

Abrasive belts

Benchstand and backstand belts



Application examples

Benchstand belts

- Stationary machine for light to moderate duty use.
- Most machines are sanding attachments to bench grinders.
- Versatile, low powered machines for general purpose use.
- Grinding and finishing against platen or contact wheel.

Backstand belts

- Stationary, heavy-duty machine.
- Deburring, blending and finishing.
- Work performed at contact wheel for most aggressive action.
- Grinding and finishing castings and forgings.

Recommendation for use

Recommendations for use of these belts under various operating conditions, as well as belt/grinder compatibility information, are given in the table "Recommendations for use of abrasive belts" (page 38).

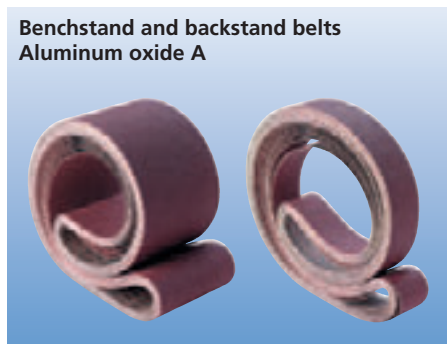
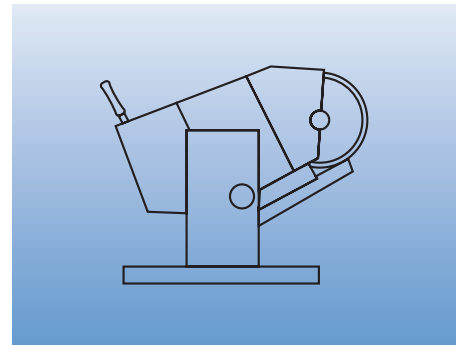
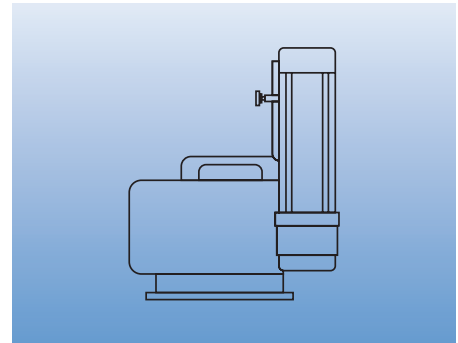

For general-purpose grinding, from coarse to fine in diverse applications.

Abrasive: Aluminum oxide A

PFERD specification number
BA-A

| Width x length [Inches] | Grit and EDP number | | | | | | |  |
|----------------------------|---------------------|-------|-------|-------|-------|-------|-------|---|
| | 24 | 36 | 40 | 50 | 60 | 80 | 120 | |
| Benchstand belts | | | | | | | | |
| 1 x 42 | - | - | 49093 | 49094 | 49095 | 49096 | 49098 | 10 |
| 1-1/2 x 60 | - | - | 49106 | - | 49108 | 49109 | - | 10 |
| 2 x 48 | - | 49132 | 49133 | 49134 | 49135 | 49136 | 49138 | 10 |
| 2-1/2 x 60 | - | 49179 | - | 49181 | 49182 | 49183 | - | 10 |
| 4 x 36 | - | - | 49373 | - | 49375 | 49376 | 49378 | 10 |
| 6 x 48 | 49463 | 49464 | 49465 | 49466 | 49467 | 49468 | 49470 | 10 |
| Backstand belts | | | | | | | | |
| 2 x 132 | - | 49159 | - | - | 49162 | 49163 | - | 10 |