



The range of PFERD crimped wire wheel brushes includes small diameter copper centre brushes, narrow, medium and wide face wheels as well as bench and pedestal grinder brushes in carbon steel, stainless steel (INOX) and brass filaments.

Crimped wire wheels

- Heavy fill density for more wire points, which means more brushing action and longer life.
- Designed for seamless gang mounting without parting lines.
- Uniform wire distribution for optimal balance and finish.
- Standard and long trim options on popular diameters as catalogue items.

Application guidelines

- Using as fine a wire as will perform the job satisfactorily will result in longer brush life. Greater wire fatigue and breakage is more likely to occur when coarser wire is used.
- Longer trim length increases brush flexibility.
- Use the appropriate adapter style to achieve the desired arbor hole size (see page 66).
- Small diameter copper centre wheels can be gang-mounted on drive arbors (see page 67) to achieve a wider brush face.
- For additional operating guidelines, please see page 15-16.



These small diameter wire wheel brushes are designed for use in restricted or hard-to-reach areas. They are excellent brushes for deburring, blending, and cleaning of surfaces and cavities.

Recommendation for use

Suitable tool drives: straight grinders, flexible shafts, power drills.

Ordering note

For drive arbors and adapters, please refer to pages 66-67.

Made in the USA.

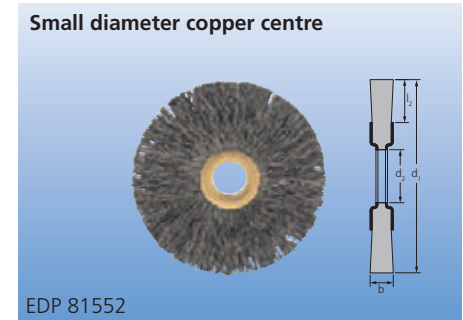

Dia. d ₁ [Inches]	Arbor hole d ₂ [Inches]	Trim length l ₂ [Inches]	Face width b [Inches]	Width on arbor [Inches]	Included adapter [Inches]	Wire diameter and EDP number					Recom. speed [RPM]	MSFS max. [RPM]	Adapter style	
						.006	.008	.010	.012	.014				
Carbon steel wire														
1	1/4	1/4	3/16	7/32	-	81500	-	-	-	-	10,000 - 15,000	20,000	F	10
1-1/4	1/4	3/8	1/4	7/32	-	81503	81504	-	-	-	10,000 - 15,000	20,000	F	10
1-1/2	3/8	7/16	1/4	7/32	-	81514	81515	-	81517	81518	10,000 - 15,000	20,000	F	10
2	1/2	1/2	3/8	7/32	3/8	81526	81527	-	81529	81530	10,000 - 15,000	20,000	F	10
2-1/2	1/2	3/4	1/2	5/16	3/8	-	-	-	81534	81535	10,000 - 15,000	20,000	F	10
3	1/2	1	5/8	5/16	3/8	81542	81543	81544	81545	81546	10,000 - 15,000	20,000	F	10
3	5/8	15/16	5/8	5/16	-	-	81549	-	-	81552	10,000 - 15,000	20,000	F	10
4	5/8	1-1/2	1/2	5/16	-	-	81553	-	-	81554	5,000 - 7,500	10,000	F	10
Stainless steel wire (INOX)														
1-1/2	3/8	7/16	1/4	7/32	-	81568	-	-	-	-	8,000 - 13,000	20,000	F	10
2	1/2	1/2	3/8	7/32	3/8	81575	-	81577	81578	81579	8,000 - 13,000	20,000	F	10
3	1/2	1	5/8	5/16	3/8	81586	81587	81588	81589	81590	8,000 - 13,000	20,000	F	10

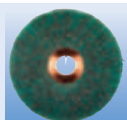

ECAP® encapsulated copper centre brushes offer more aggressive brushing. See page 21.