

Instructions and Parts List

Scotch®

Box Sealing Tape Dispenser HR 80 (2 inch) HR 83 (3 inch)

Model 11000

Description

The **Tape Dispenser HR 80 / HR 83** provides a quick and easy method for dispensing **Scotch® Box Sealing Tapes** directly from the roll. This lightweight, hand-held, portable dispenser is recommended for center seam sealing of RSC boxes.

Specifications

Tape:

For use with most **Scotch® Box Sealing Tapes**.

Tape Widths:

HR 80 - 2 inch or 55mm max

HR 83 - 3 inch or 72mm max

Tape Roll Diameter:

Up to 5-1/8 inch [130mm] maximum on a 3 inch [76.2mm] diameter core.

Overall Dimensions:

Length: 5 3/4 inches [145mm]

Height: 10 inches [255mm]

Width: HR 80 - 2 3/4 inches [70mm]

HR 83 - 3 3/4 inches [95mm]

Weight: Packaged 1.45 lbs. [0.65 kg]

Unpackaged 1.25 lbs. [0.56 kg]

Loading Instructions

Figure 1 - Place tape roll fully onto tape drum to dispense tape forward from top of roll. Pull tab to remove and discard blade protection.

Figure 2 - Pivot brake to open position. Thread tape between roller and brake.

Figure 3 - Bring tape up and around roller and pull back slightly to one side to cut off excess tape. Adjustable tape roll tension provided.

Operating Instructions (Figure 4)

- Place tape and applicator roller on box front corner (centered on top seam). Roll dispenser down to tack tape lead end to side of box.
- Pull dispenser across box top seam applying pressure to applicator roller in order to obtain a tight seal.
- Continue tape web 2 1/2 to 3 inches or 65 to 75mm past end of box.
- Bring dispenser tape wipe-down plate against the corner of the box. Push down while slightly twisting to cut and wipe tape end to back side of boxes.

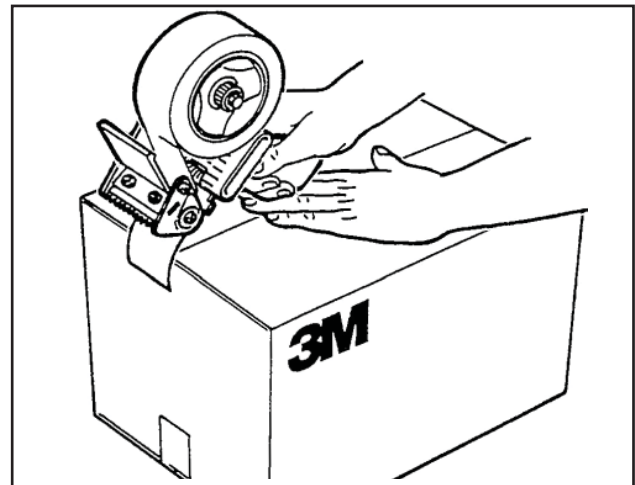

Box Sealing Tape Dispenser HR 80 / HR 83

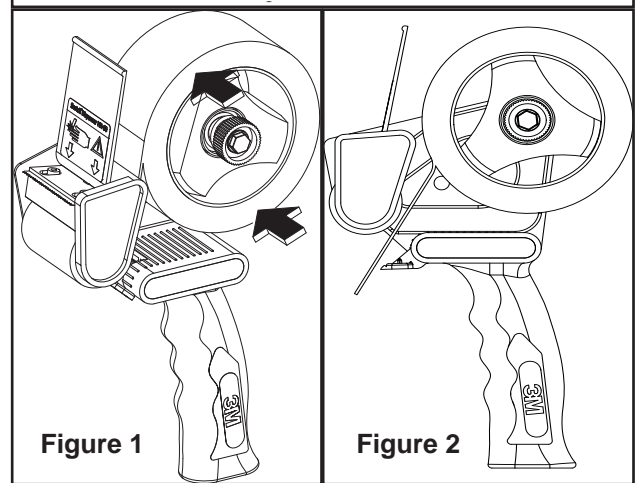

Figure 1

Figure 2

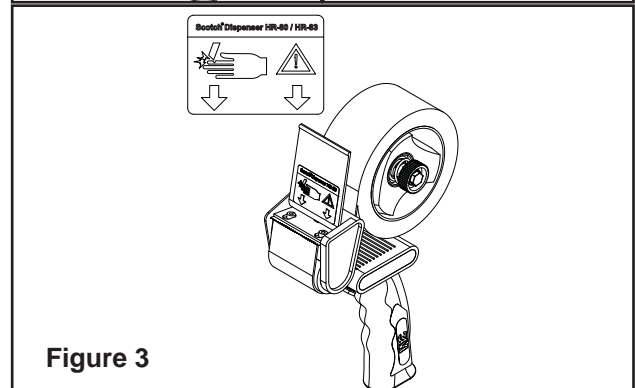

Figure 3

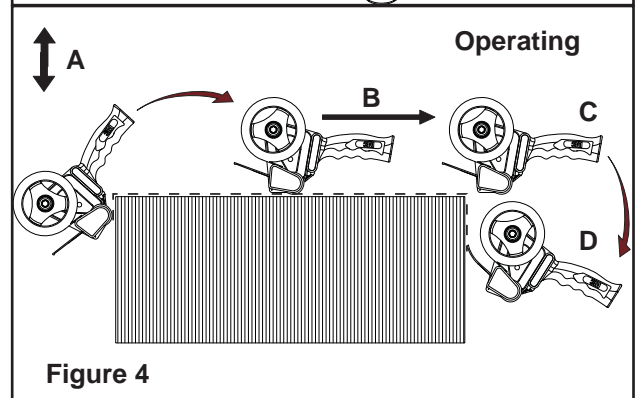
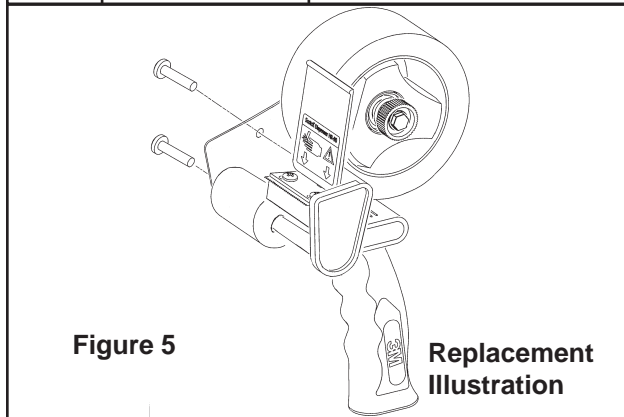

Figure 4

Replacement Parts List

Model	Part Number	Description
HR 80	78-8137-3530-1	2" Blade/Wiper Assembly
HR 83	78-8137-3531-9	3" Blade/Wiper Assembly



How To Replace the Wiper and Blade Assembly

1. Remove screws to detach used wiper and blade assembly.
2. Install new wiper and blade assembly with serrated cutting edge pointing away from applicator roller.
3. Replace and tighten screws to secure new wiper and blade assembly (**Figure 5**).

Minimum billing on parts orders is \$25.00. Replacement part prices available on request.
\$10.00 restocking charge per invoice on returned parts.

Outside the U.S., contact the local 3M subsidiary for parts ordering information.

Equipment Warranty and Limited Remedy: THE FOLLOWING WARRANTY IS MADE IN LIEU OF ALL OTHER WARRANTIES, EXPRESS OR IMPLIED, INCLUDING, BUT NOT LIMITED TO, THE IMPLIED WARRANTY OF MERCHANTABILITY, THE IMPLIED WARRANTY OF FITNESS FOR A PARTICULAR PURPOSE AND ANY IMPLIED WARRANTY ARISING OUT OF A COURSE OF DEALING, A CUSTOM OR USAGE OF TRADE:

3M warrants that its **Scotch® Box Sealing Equipment** will be free from defects for ninety (90) days after delivery. If any part is proved to be defective within the warranty period, then the exclusive remedy and 3M's and seller's sole obligation shall be, at 3M's option, to repair or replace the part, provided the defective part is returned immediately to 3M's factory or an authorized service station designated by 3M. A part will be presumed to have become defective after the warranty period unless the part is received or 3M is notified of the problem no later than five (5) calendar days after the warranty period. If 3M is unable to repair or replace the part within a reasonable time, then 3M, at its option, will replace the equipment or refund the purchase price.

Limitation of Liability: 3M and seller shall not be liable for direct, indirect, special, incidental or consequential damages based upon breach of warranty, breach of contract, negligence, strict liability or any other legal theory.

The foregoing Equipment Warranty and Limited Remedy and Limitation of Liability may be changed only by a written agreement signed by authorized officers of 3M and seller.

Industrial Adhesives and Tape Division

3M Center, Building 220-5E-06
St. Paul, MN 55144-1000
1-800-362-3550
www.3M.com/packaging

 WARNING
<ul style="list-style-type: none"> • To reduce the risk associated with sharp blade hazards: <ul style="list-style-type: none"> – Keep hands and fingers away from tape cutoff blade. The blade is extremely sharp.

How To Order Replacement Parts

1. Refer to parts list for correct part number.
2. Order by **description, dispenser name, and part number.**
3. Replacement parts and part prices available direct from:

3M Tape Dispenser Parts
241 Venture Drive
Amery, WI 54001-1325

800-344-9883
Fax: 715-268-8153

"Scotch" is a trademark of 3M Company
"3M" is a trademark of 3M Company,
St. Paul, Minnesota 55144-1000

Printed in U.S.A.

© 3M 2011 44-0009-2199-9 (C042911-NA)