

3M Welding Shield WS Series

User Instructions for

- *3M™ Welding Shield with Auto-Darkening Filter, Variable Shade #10-12 WS-320*
- *3M™ Welding Auto-Darkening Filters, Variable Shade #10-12 WS-020*
- *3M™ Welding Shield with Standard Glass Filter Plate, Shade #10 WS-110*

Important: Keep these *User Instructions* for reference.

WARNING

- These products are designed to help protect the wearer's eyes from harmful radiation including visible light, ultra-violet radiation (UV) and infra-red radiation (IR) resulting from certain arc-welding processes when used in accordance with these *User Instructions*. Use of this product in any other application such as gas welding (oxy-acetylene) or laser welding **may result in permanent eye injury and vision loss**. Do not use any welding product without appropriate training. For proper use, see supervisor, or *User Instructions* or call 3M in U.S.A. 1-800-243-4630. In Canada, call Technical Service at 1-800-267-4414.
- Always wear ANSI Z87.1-2003 compliant safety spectacles in addition to any welding shield. Failure to do so **may result in permanent eye injury and vision loss**. In Canada, follow CSA Z94.3 and/or the requirements of the authority having jurisdiction in your region.
- Before each use, perform the inspection described in these *User Instructions* to ensure that all components are installed and functioning as intended. Use of 3M™ welding shield assemblies that do not meet these inspection requirements **may result in permanent eye injury and vision loss**.
- Should the 3M™ Auto Darkening Filter (ADF) fail to switch to dark mode upon striking an arc, stop welding immediately and inspect the ADF as described in these *User Instructions*. Continued use of an ADF that fails to switch to the dark state **may result in permanent eye injury and vision loss**. If the problem cannot be identified and corrected, do not use the ADF; contact your supervisor, distributor or 3M for assistance.
- Do not use welding filters that are cracked, pitted or otherwise damaged as these conditions may compromise eye/face impact protection and may allow harmful UV and IR radiation to pass through **causing permanent eye injury and vision loss**.
- **Severe burn injuries may result** if these welding shields are used for heavy-duty overhead welding applications where there is a potential for falling molten metal.

- Only operate these ADFs at temperatures between 23°F (−5°C) and 131°F (+55°C). If used outside of this range, the filter may not perform as designed and **may result in permanent eye injury and vision loss.**

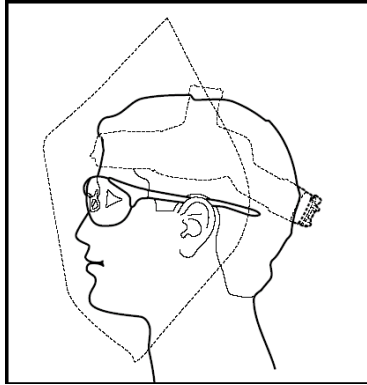

GENERAL SAFETY INFORMATION

This product contains no components made from natural rubber latex.

Intended Use

The 3M™ Welding Shield Assemblies WS Series are designed to help protect the wearer's eyes from harmful radiation including visible light, ultra-violet radiation (UV) and infrared radiation (IR) resulting from certain arc-welding processes when used in accordance with these *User Instructions*. Two sensors on the front of the ADF WS Series react independently at the moment the welding arc is struck and cause the filter to darken. The ADF switches back to the light shade (shade 4) as soon as the welding arc has stopped. Two lithium batteries are used as the power source. The ADF will switch off automatically approximately 30 minutes after the last arc is detected. Protection from ultra-violet radiation (UV) and infrared radiation (IR) is continuous, whether the ADF is in the light or the dark state. In the event of battery or electronic failure, the welder remains protected against UV and IR radiation according to the darkest shade (shade 12).

3M™ ADFs allows the welder to view their work clearly and safely during set-up, during the weld and after without interruption and without the burden or delay of manually lifting the shield or filter. 3M ADFs allow manual arc welding to be performed more quickly and accurately in comparison to traditional passive welding filter plates.

Important Use Limitations:

- These products do not provide any protection from respiratory hazards that may result from welding processes or from other sources. 3M™ Welding Shields WS Series may be worn in conjunction with certain respirator models. For more information about respiratory protection for welders, contact 3M Technical Service at 1-800-243-4630. In Canada, call Technical Service at 1-800-267-4414.
- The ADF WS-020 is not suitable for gas welding (e.g., oxyacetylene), low-amperage TIG welding (below 20 amps), laser welding, or welding processes that require shade 13 or higher filters. Use of this product for these applications **may result in permanent eye injury and vision loss.**
- Only operate the ADF at temperatures between 23°F (−5°C) and 131°F (+55°C). If used outside of this range, the filter may not perform as designed and **may result in permanent eye injury and vision loss.**

SPECIFICATIONS

ADF Switching time	Less than 0.4 milliseconds (or 1/2500 second)
Selectable Shades	10, 11 and 12
ADF Light state	Shade 4
ADF Ultraviolet/Infrared	Protection at all times - non-switching
ADF Battery life	Average 1,500 hours on new CR 2032 battery
ADF Use temperature	-5°C (23°F) to +55°C (+131°F)
ADF Viewing area	3.5 in. x 1.6 in. (90 mm x 42 mm)
ADF Auto off	After 60 minutes without arc detection
Head sizes	Fits hat sizes 6 (Small) through 7 ½ (X Large)
Shield and Retainer Material	Polypropylene
ADF Housings	Polyamide nylon

REPLACEMENT PARTS AND ASSEMBLIES

WS-320	3M™ Welding Shield with Auto-Darkening Filter, Variable Shade #10 thru #12
WS-110	3M™ Welding Shield with Standard Glass Filter Plate, Shade #10
WS-020	3M™ Welding Auto-Darkening Filter Only, Variable Shade #10 thru #12
L-152-5	3M™ Welding Filter Outside Protection Plate (all welding filters)
L-162-2	3M™ Welding Shield Inside Safety Plate - for standard glass filter plates only
WS-351	3M™ Welding Shield Head Suspension
L-115-10	3M™ Welding Shield Sweat Pad
WS-353	3M™ Welding Shield Suspension Pivot and Knob Kit
WS-354	3M™ Welding Shield and Retainer (no head suspension)
WS-352	3M™ Welding Shield Filter Retainer
WS-355	3M™ Welding Filter Spacer Plate
WS-363	3M™ Inside Protection Plate (for WS-020 ADF only)
WS-356	3M™ Welding Filter Battery Holder
04-0320-00	Batteries, type CR-2032 (2-pack)

ASSEMBLY AND ADJUSTMENT

3M™ Welding Shield

Adjusting head band size (Fig. 1)

The ratchet adjustment can be set to the correct head size by pushing the hand-wheel in and turning. The adjustment position is locked when the hand-wheel is released.

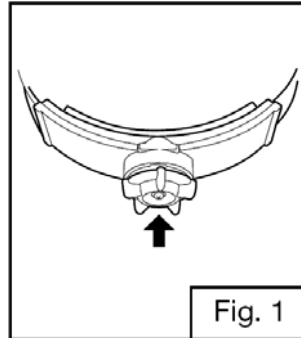

Adjusting the Stop Angle of the Shield (Fig. 2 & 3)

The angle that the welding shield stops when lowered for welding can be adjusted by repositioning the stud in the shield to one of the four holes in the stop angle adjustment tab as shown. (Fig. 2) The pivot friction knob must be loosened before performing this adjustment. The shield should be adjusted so that the welding filter is perpendicular to the line of sight between the welder's eye and the welding position. (Fig. 3) If the correct angle cannot be obtained without the welding shield being too close to the face, the front-back position should be adjusted outward as shown. (Fig. 4)

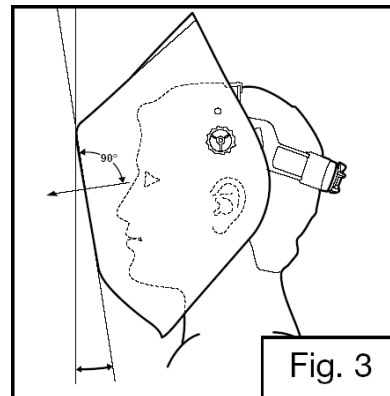
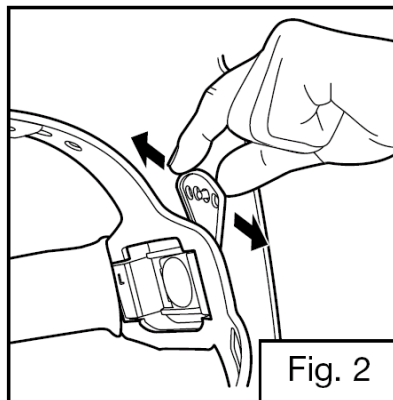

Adjusting the Front-Back Position

To adjust the distance between the users face and the welding shield, the pivot bushing can be positioned to the front or back of the notched slots. The pivot friction knob must be removed in order to complete this adjustment. (Fig. 4)

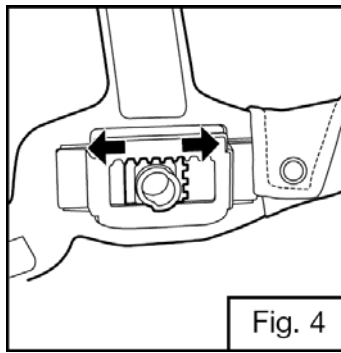

Adjusting the Pivot Friction (Fig. 5)

Adjust the pivot friction by tightening or loosening the pivot knobs on either side of the welding shield. Adjust both knobs evenly.

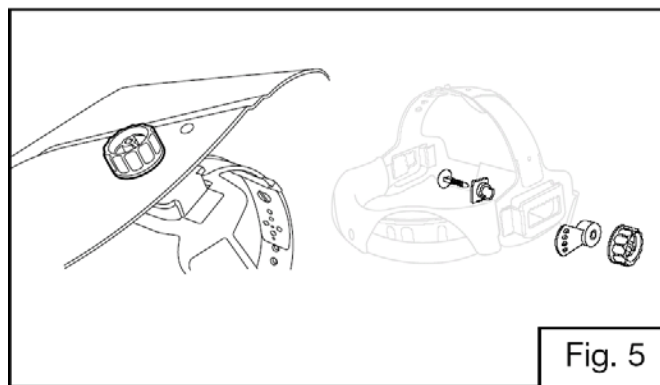

Assembling Standard Glass Filter Plate (Fig. 6)

Install the 3M™ Inside Safety Plate L-162-2, ANSI compliant standard glass filter plate, 3M™ Spacer Gasket WS-355 and 3M™ Cover Plate L-152-5 as shown in the figure below. Then install the 3M™ Retainer Bracket WS-352 with the arrow facing up until its four legs are fully engaged in the sockets in the shield and the stack assembly is firmly held in place.

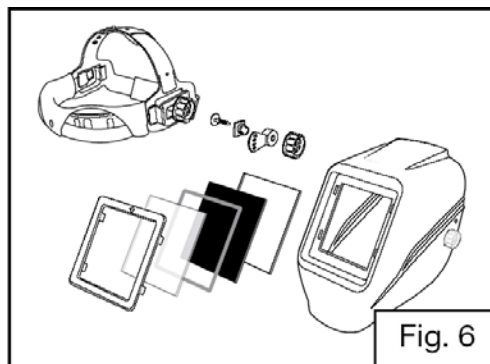

Assembling the ADF WS-020 (Fig. 7)

While holding the shield with the shield opening facing up, insert the ADF (complete with 3M™ Inside Protection Plate WS-363) and cover plate L-152-5 into the center of the shield opening. The photo-sensors should be at the top and facing out. Install the filter retainer WS-352 bracket with the arrow facing up until its four legs are fully engaged in the sockets in the shield and the stack assembly is firmly held in place.

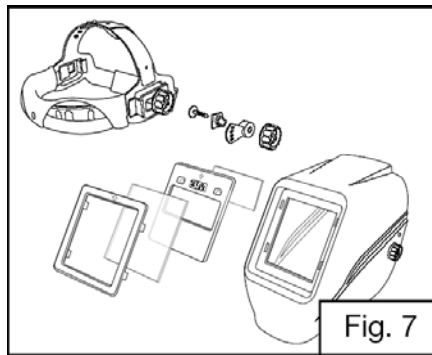

Fig. 7

Removal of Welding Filters (Fig. 8)

Hold the shield just above a horizontal surface so the welding filter does not fall and break. From the inside of the welding shield, pull inward on the protruding portion of the retainer bracket legs until their teeth disengage, then push each of the legs through until the retainer bracket is fully disengaged from the shield.

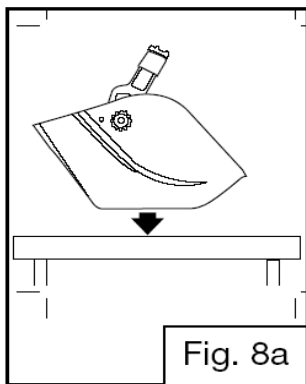

Fig. 8a

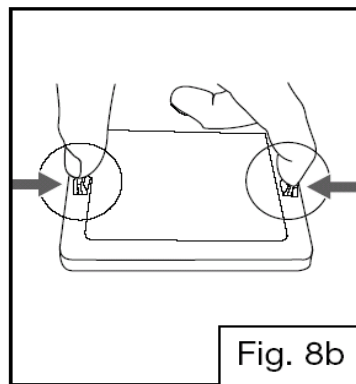

Fig. 8b

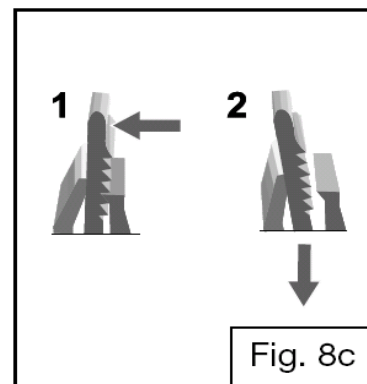

Fig. 8c

ADF FUNCTION



On/Off

To activate the welding filter, press the ON button. After each short press of the ON button, the current settings (shade and sensitivity) are displayed by flashing LED's. The welding filter automatically switches off approximately 30 minutes after the last welding arc is detected. The welding filter can also be switched off manually by pressing the ON button for a few seconds.

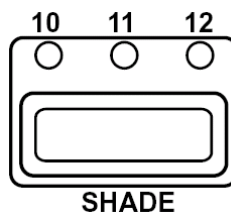

Shade Selection

Three different shade settings are available in the dark state, 10, 11 and 12. In order to see the current ADF shade setting, momentarily press the Shade button. To select another shade, press the Shade button again while the LED

is flashing, and then keep pressing the button until the LED shows the desired shade. Use the appropriate shade for the type of welding to be performed as recommended by ANSI Standard Z49.1-2003. (Table 1)

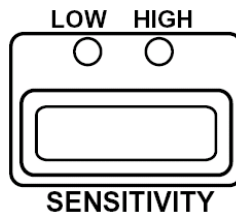

Sensitivity Selection

Press the sensitivity button once to show the current sensitivity setting on the LED scale. Continue pressing the sensitivity button to switch between high and low sensitivity. The sensitivity adjustment controls the amount of light needed to trigger the ADF to the selected dark shade. In order to find a suitable sensitivity setting, start on LOW. This setting is suitable for most applications. If the filter does not darken during welding as desired, change the sensitivity to HIGH. If more than one person is welding in an area, “false triggering” may occur when the light from one welder's arc triggers the filter of another welder. If false triggering cannot be solved by changing sensitivity, the 3M™ ADF WS-020 may not be suitable for the application.

LOW: Normal position. Used for most types of welding indoors and outdoors.

HIGH: Position for welding with low current or stable arcs. (e.g. TIG welding at low amps).

Replacement of 3M™ Inside Protection Plate WS-363 (Fig. 9)

Remove the inside protection plate as illustrated. (Fig. 9) The new inside protection plate is assembled after the protective film is removed. Insert one side under the corner retainers. Bend the middle part as necessary to insert the other side.

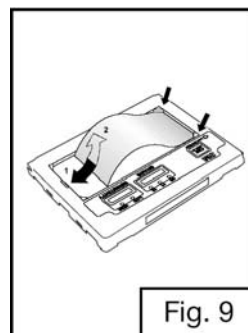

Fig. 9

Battery Replacement (Fig. 10)

The “low battery” indicator flashes repeatedly when the battery should be replaced. The welding filter must be removed before battery replacement can be carried out. Take out the battery holder (a small screwdriver can be used if necessary). Remove the used batteries and dispose of them according to the local regulations. Insert two new CR-2032 batteries in the battery holder. (Fig. 10) Push the battery holder into the welding filter until it snaps in position.

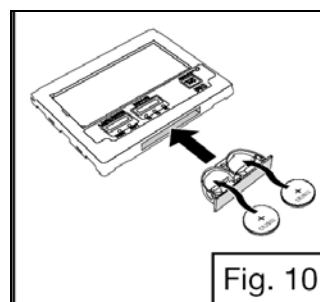

Fig. 10

INSPECTION

Carefully inspect welding filters before each use. Cracked, pitted or scratched filter glass or protection plates can seriously impair protection and reduce vision. The sensors on the ADF must be kept clean and uncovered at all times to provide correct function. Check for cracks in the shield and look for light leaks. All damaged components should be replaced immediately.

WARNING

- Before each use, perform the inspection described in these *User Instructions* to ensure that all components are installed and functioning as intended. Use of 3M™ welding shield assemblies that do not meet these inspection requirements **may result in permanent eye injury and vision loss.**
- Do not use welding filters that are cracked, pitted or otherwise damaged as these conditions may compromise eye/face impact protection and may allow harmful UV and IR radiation to pass through **causing permanent eye injury and vision loss.**

CLEANING AND STORAGE

Clean the welding shield with mild soap and lukewarm water. Do not use solvents. Clean the welding filter with a clean, lint-free tissue or cloth. Do not immerse ADFs in water or spray directly with liquids.

Store equipment in a clean dry and dust-free environment at room temperature.

Table 1. Recommended Guide for Shade Numbers (Adapted from ANSI Z49.1-1999)				
Operation	Electrode diameter inches	Arc current, amps	Minimum Protective Shade	Recommended Shade Number
Shielded metal arc	< 3	< 60	7	---
	3-5	60-160	8	10
	5-8	160-250	10	12
	> 8	250-550	11	14
Gas-metal-arc welding		< 60	7	---
		60-160	10	11
		160-250	10	12
		250-500	10	14
Gas-tungsten-arc		< 50	8	10
		50-150	8	12
		150-500	10	14
Air-carbon-arc cutting		< 500	10	12
		500-1000	11	14
Plasma-arc welding		< 20	6	6-8
		20-100	8	10
		100-400	10	12
		400-800	11	14

Plasma-arc cutting		< 300	8	9
		300-400	9	12
		400-800	10	14
Torch brazing				3-4
Torch soldering				2
Carbon arc welding				14
Plate thickness, inches				
Gas welding	< 1/8			4-5
	1/8-1/2			5-6
	> 1/2			6-8
Oxygen cutting	< 1			3-4
	1-6			4-5
	> 6			5-6

WARRANTY

3M warrants Welding Filters WS Series for 24 months from the date of purchase against all manufacturing defects resulting from materials or workmanship (proof of purchase required). This warranty is void in case of operator misuse, abuse, or neglect. Read these User Instructions to avoid certain situations, which could void this warranty (for example, cracked filters and filters covered with weld spatter are not covered under the warranty policy).

FOR MORE INFORMATION

In United States, contact:

Internet: www.3M.com/occsafety

Technical Assistance: 1-800-243-4630

For other 3M products:

1-800-3M-HELPS or 1-651-737-6501

3M Occupational Health and Environmental Safety Division

3M Center, Building 0235-02-W-70

St. Paul, MN 55144-1000

©3M 2005

38-9018-6400-9