

SH. 1
OF 1

CAT NO

1126-36

CUSTOMER DIMENSIONS

DO NOT
SEPARATE
PRINT FROM
WORK

LOT NO

OPER

TOOLS

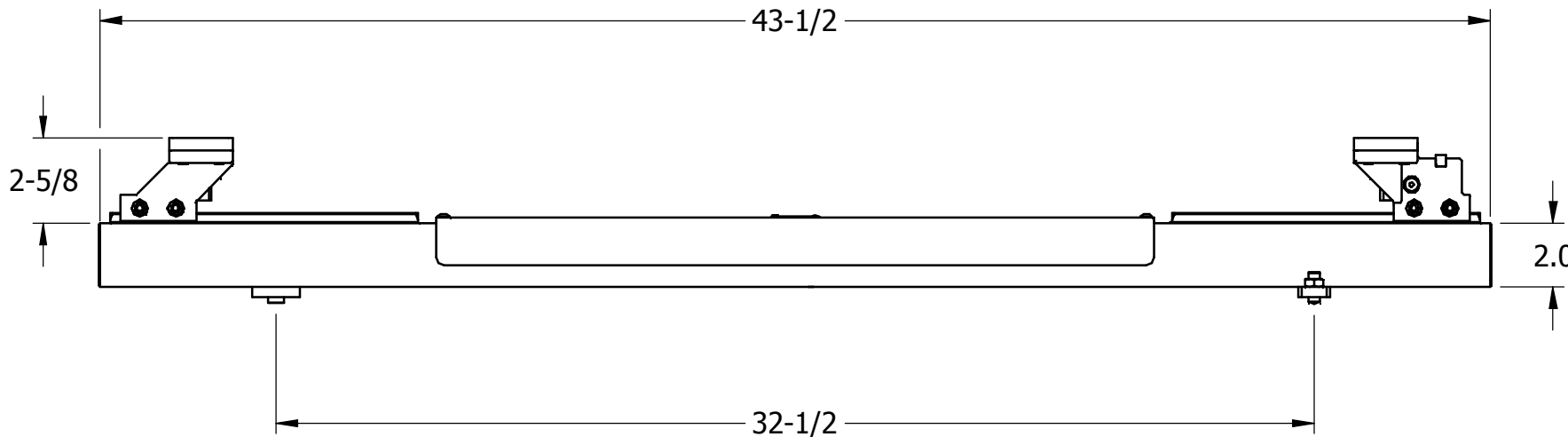
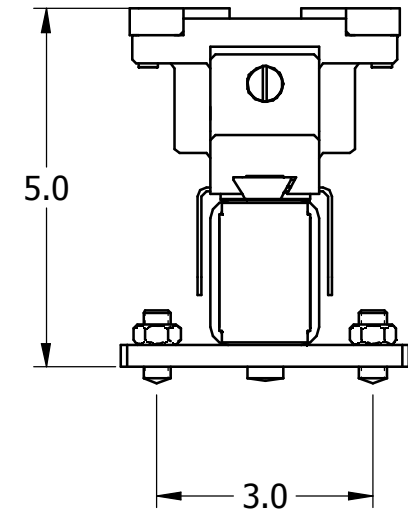
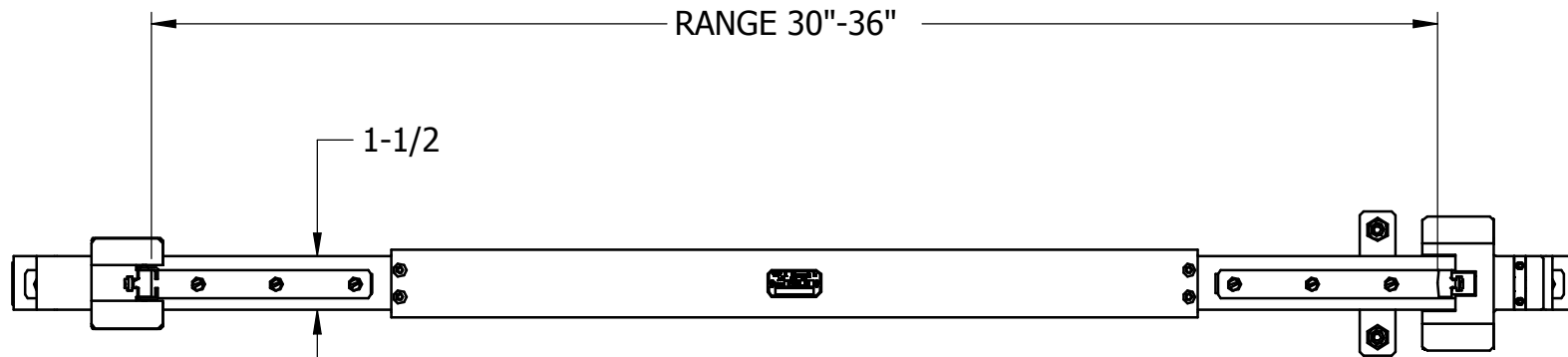

| | | | |
|--|--|--|--|
| | | | |
| | | | |
| | | | |
| | | | |
| | | | |

| REV | DESCRIPTION | DATE | BY |
|-----|-------------|------|------|
| DR | WEN | CHK | DATE |

INTERNAL - EXTERNAL
SETTING MASTER
RANGE 30" - 36"

THE L.S. STARRETT CO.
ATHOL, MASS.

FRACTIONAL TOLERANCE +- 1/64 UNLESS OTHERWISE NOTED