

SH. 1
OF 1

CAT NO

207Z

CUSTOMER DIMENSIONS

DO NOT
SEPARATE
PRINT FROM
WORK

LOT NO

OPER

TOOLS

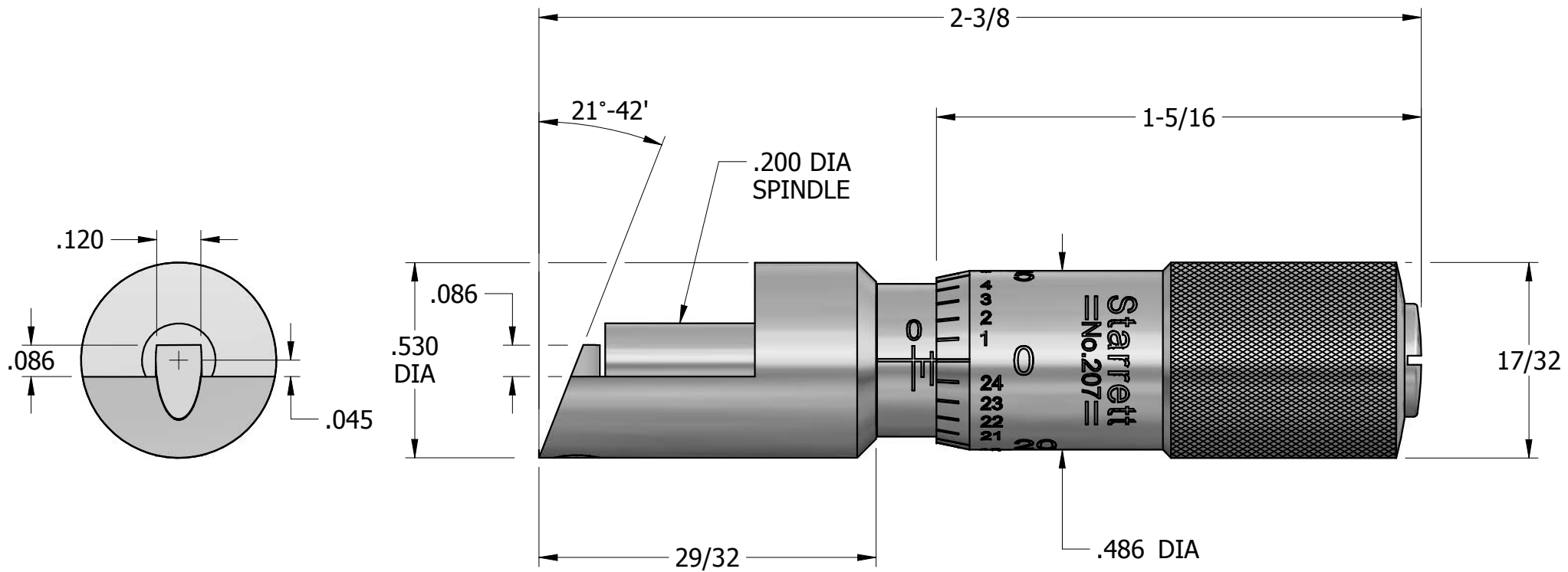

| | | | |
|-----|------------------------|---------|--------------|
| | | | |
| | | | |
| | | | |
| | | | |
| | | | |
| | | | |
| B | ADD'D ADDITIONAL DIM'S | 3/30/15 | CAP |
| REV | DESCRIPTION | DATE | BY |
| DR | CAP | CHK | DATE 3/30/15 |

STAINLESS STEEL
CAN SEAM MICROMETER

THE L.S. STARRETT CO.
ATHOL, MASS.

FRACTIONAL TOLERANCE +- 1/64 UNLESS OTHERWISE NOTED