

SH. 1  
OF 1

CAT NO

56C

CUSTOMER DIMENSIONS

DO NOT  
SEPARATE  
PRINT FROM  
WORK

LOT NO

OPER

TOOLS

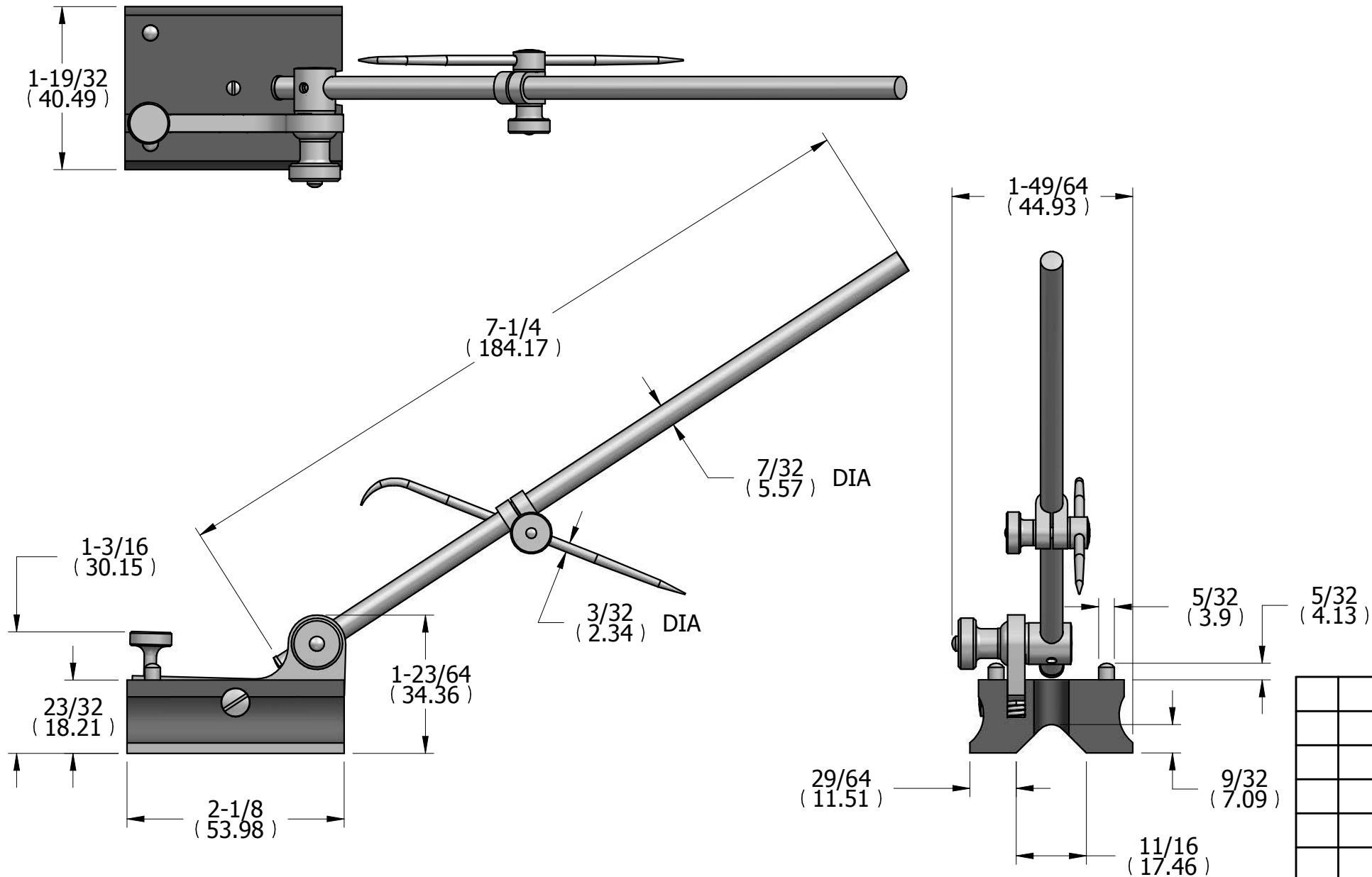

SHOWN WITH SPINDLE AT 45°  
AND GUIDE PINS IN "UP" POSITION

REV	DESCRIPTION	DATE	BY
-----	-------------	------	----

DR	HS	CHK	DATE
----	----	-----	------

**SURFACE GAGE  
ASSEMBLY**

**THE L.S. STARRETT CO.  
ATHOL, MASS.**

FRACTIONAL TOLERANCE  $\pm 1/64$  UNLESS OTHERWISE NOTED