

SH. 1  
OF 1

CAT NO

579D

CUSTOMER DIMENSIONS

DO NOT  
SEPARATE  
PRINT FROM  
WORK

LOT NO

OPER

TOOLS

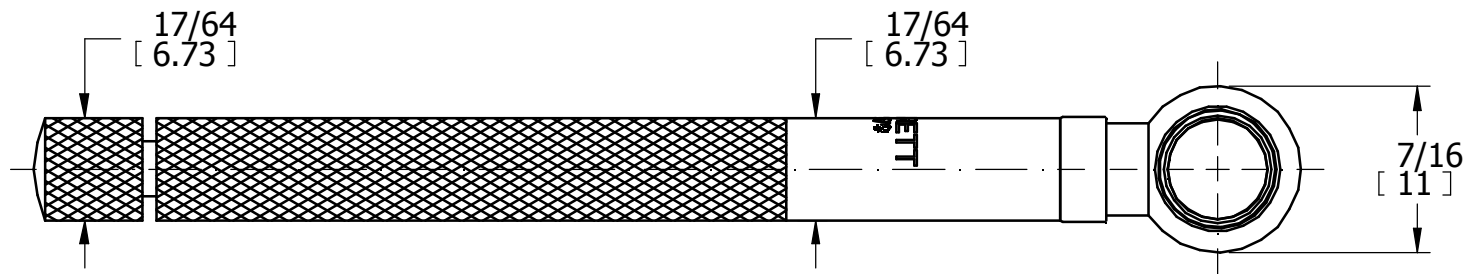
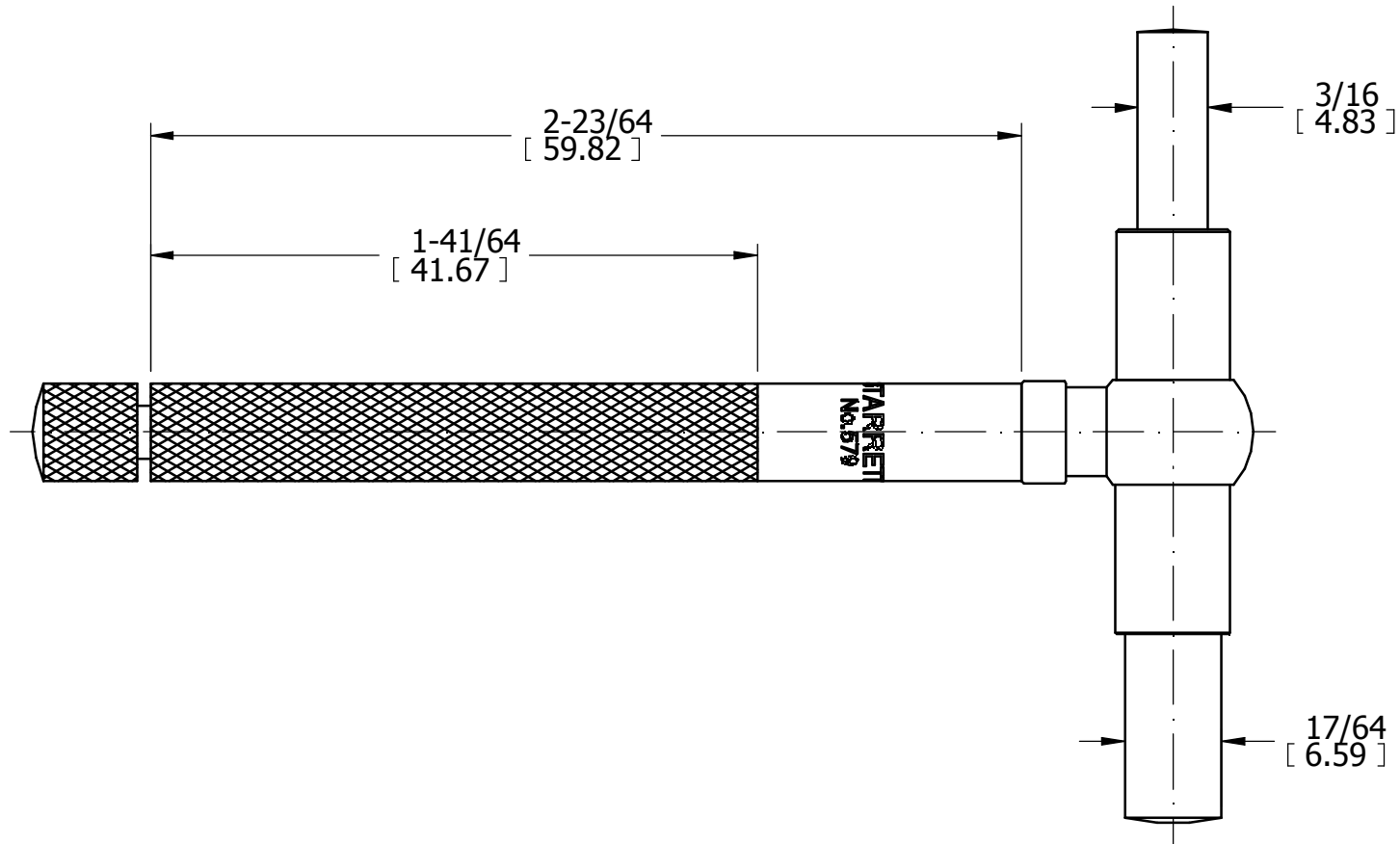

REV	DESCRIPTION	DATE	BY
DR	JSH	CHK	DATE

TELESCOPING GAGE  
ASSEMBLY

THE L.S. STARRETT CO.  
ATHOL, MASS.

FRACTIONAL TOLERANCE  $\pm 1/64$  UNLESS OTHERWISE NOTED