

SH. 1  
OF 1

PT NO PT99430

MAT'L

CUSTOMER DIMS

DO NOT  
SEPARATE  
PRINT FROM  
WORK

OUTSIDE PROCESS  
SEE SHEET

OPER

TOOLS

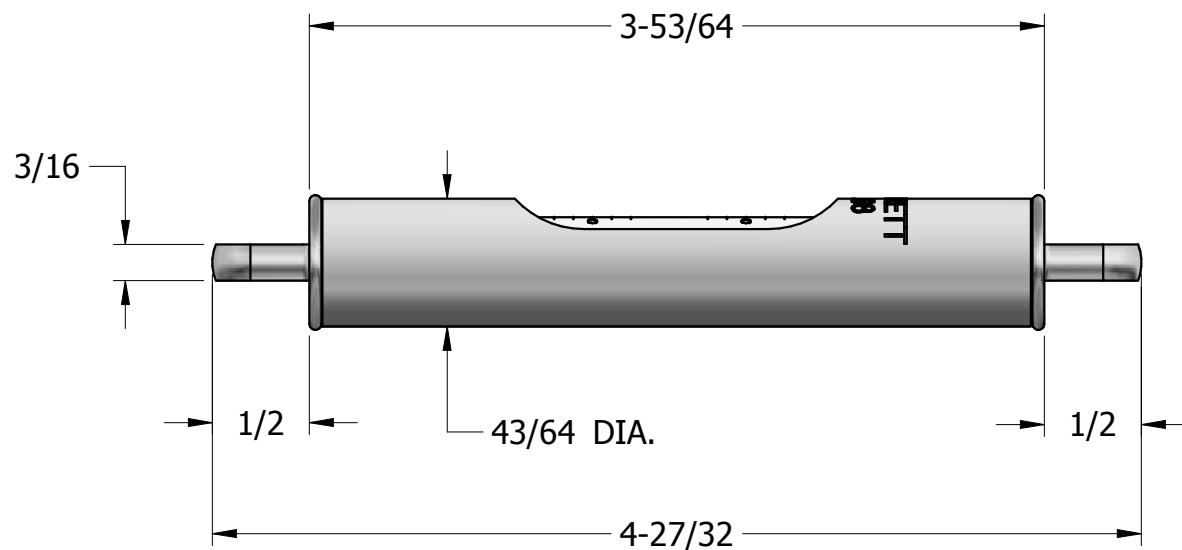
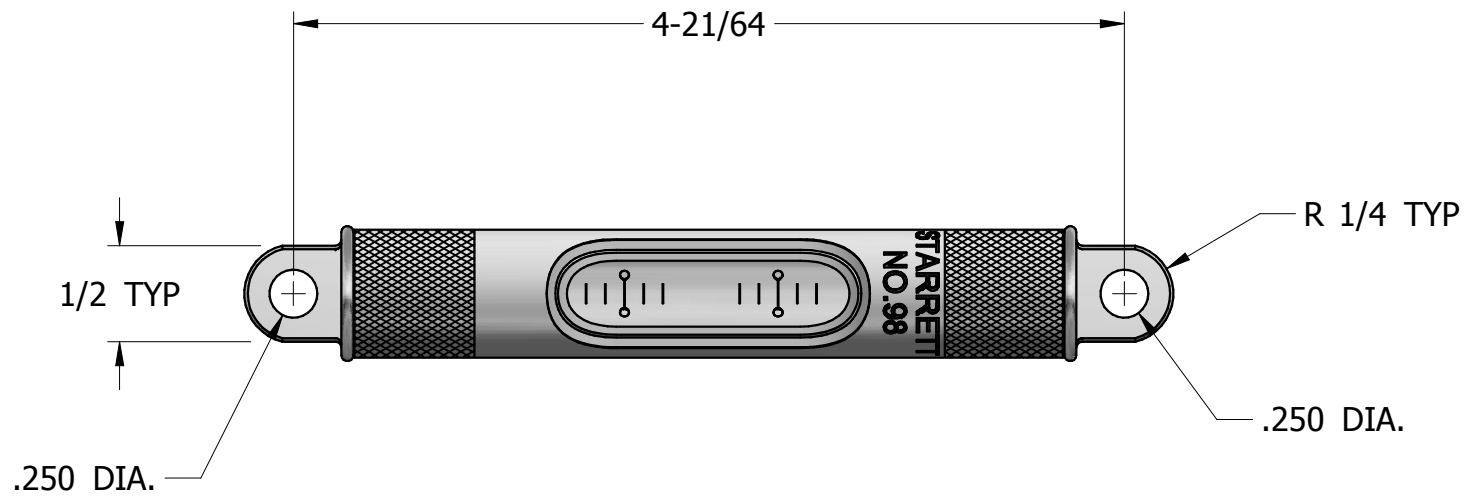

A	AS RELEASED	5/5/17	SMB
REV	DESCRIPTION	DATE	BY
CAT NO	98	SIZE	6"
DR	SMB	CHK	DATE 5/5/17
TUBE/PLUG, CAT. 98-6			

TOLERANCES - UNLESS  
OTHERWISE SPECIFIED

1 PLACE DEC. or REF. : +/- .015" --- 0.4 mm  
2 PLACE DEC. : +/- .010" --- 0.25 mm

3 PLACE DEC. : +/- .003" --- 0.08 mm  
4 PLACE DEC. : +/- .0005" --- 0.01 mm

FRACTIONAL: +/- 1/64"  
ANGULAR: +/- 1 DEGREE

THE L.S. STARRETT CO.  
ATHOL, MASS.